

STR800 SmartLine Remote Diaphragm Seals Specification 34-ST-03-88, October 2023



Introduction

Part of the SmartLine® family of products, the STR800 is a series of high performance pressure transmitters hydraulically matched and optimized with a complete set of remote diaphragm seals. Utilizing the same high performance sensor technology of the ST 800 product line Honeywell has optimized the mechanical and hydraulic designs in order to minimize the typical effects of temperature on remote seal systems. The SmartLine family is also fully tested and compliant with Experion® PKS providing the highest level of compatibility assurance and integration capabilities. SmartLine easily meets the most demanding application needs for pressure measurement applications.

Best in Class Features:

- Accuracies of up to 0.0375% of span.
- Automatic static pressure & temperature compensation.
- Rangeability up to 100:1.
- Multiple local display capabilities.
- External zero, span, & configuration capability.
- Polarity insensitive electrical connections.
- Comprehensive on-board diagnostic capabilities.
- Integral Dual Seal design for highest safety based on ANSI/NFPA 70-202 and ANSI/ISA 12.27.0.
- World class overpressure protection.
- Full compliance to SIL 2/3 requirements.
- Modular design characteristics.
- Supports NAMUR NE-107 Extended Diagnostics (FF).
- Available with an additional 15-year warranty.

Typical Diaphragm Seal applications

- High Process Temperatures.
- Viscous or Suspended Solids.
- Highly Corrosive Process Materials.
- Sanitary Applications.
- Applications with Hydrogen Permeation Possibilities.
- Level Applications with Maintenance Intensive Wet Legs.
- Applications requiring remote Transmitter Mounting.
- Tank Applications with Density or Interface Measurements.



Figure 1 – STR800 Remote Diaphragm Seal Unit

Communications/Output Options:

- Honeywell Digitally Enhanced (DE)
- HART® (version 7.0)
- FOUNDATION™ Fieldbus

All transmitters are available with the above listed communications protocols.

Span & Range Limits:

Model	URL inH ₂ O (mbar)	LRL inH ₂ O (mbar)	Min Span inH ₂ O (mbar)
STR82D	400 (1000)	-400 (-1000)	4.0 (10)
Model	psi (bar)	psi (bar)	psi (bar)
STR83D	100 (7.0)	-100 (-7.0)	1 (0.07)
STR84G	500 (35.0)	-14.7 (-1.0)	5 (0.35)
STR87G	3000 (210)	-14.7 (-1.0)	30 (2.1)
Model	psia (bara)	psia (bara)	psia (bara)
STR84A	500 (35)	0 (0)	5 (0.35)

Description

The SmartLine family of gauge pressure, differential pressure, and absolute pressure transmitters is designed around a high performance piezo-resistive sensor. This one sensor actually integrates multiple sensors linking process pressure measurement with on-board static pressure (DP Models) and temperature compensation measurements resulting in the best total performance available. This level of performance allows the ST 800 to replace virtually any competitive transmitter available today.

Unique Indication/Display Options

The ST 800 modular design accommodates a standard alphanumeric LCD display or a unique advanced graphics LCD display with many unparalleled features.

Standard LCD Display Features

- Modular (may be added or removed in the field).
- Supports HART protocol variant.
- 0, 90, 180, & 270 degree position adjustments.
- Four configurable screens.
- Standard and custom measurement units available.
- Display calculated flow (square root) value in addition to analog output signal.
- 2 Lines 6 digits PV (9.95H x 4.20W mm) 8 Characters.
- Write protect Indication.
- Built-in Basic Device Configuration through Internal or External Buttons – Range/Engineering Unit/Loop Test /Loop Calibration/Zero /Span Setting.
- Multiple language capabilities (EN, RU).

Advanced Graphics LCD Display Features

- Modular (may be added or removed in the field).
- 0, 90, 180, & 270 degree position adjustments.
- Standard and custom measurement units available.
- Up to eight display screens with 3 formats are possible.
- Large PV with Bar Graph or PV with Trend Graph.
- Configurable screen rotation timing (1 to 30 sec).
- Display calculated flow (square root) value in addition to analog output signal.
- Unique “Health Watch” indication provides instant visibility of diagnostics.
- Multiple language capability (EN, DE, FR, IT, ES, RU, TR, CN, & JP).

Diagnostics

SmartLine transmitters all offer digitally accessible diagnostics which aid in providing advanced warning of possible failure events minimizing unplanned shutdowns, providing lower overall operational costs.

Configuration Tools

Integral Three Button Configuration Option

Suitable for all electrical and environmental requirements, SmartLine offer the ability to configure the transmitter and display via three externally accessible buttons when either display option is selected. Zero/span capabilities are also optionally available via these buttons with or without selection of a display option.

Handheld Configuration

SmartLine transmitters feature two-way communication and configuration capability between the operator and the transmitter. All Honeywell transmitters are designed and tested for compliance with the offered communication protocols and are designed to operate with any standards compliant handheld configuration device, such as Honeywell Versatilis Configurator.

Personal Computer Configuration

On a personal computer or laptop, Honeywell Field Device Manager (FDM) Software and FDM Express can be used for managing HART & Fieldbus device configurations.

System Integration

- SmartLine communications protocols all meet the most current published standards for HART/DE/Fieldbus.
- Integration with Honeywell’s Experion PKS offers the following unique advantages.
 - Transmitter messaging.
 - Maintenance mode indication.
 - Tamper reporting.
 - FDM Plant Area Views with Health summaries.
 - All ST 800 units are Experion tested to provide the highest level of compatibility assurance.

Modular Design

To help contain maintenance & inventory costs, all STR800 transmitters are modular in design supporting the user’s ability to replace or add indicators, terminal connections or electronic modules without affecting overall performance or approval body certifications

Modular Features

- Exchange/replace electronics/comms modules*
- Add or remove integral indicators*
- Add or remove lightning protection (terminal connection)*

* Field replaceable in all electrical environments (including IS) except flameproof without violating agency approvals.

With no performance effects, Honeywell’s unique modularity results in **lower inventory needs and lower overall operating costs.**

Performance Specifications

Reference Accuracy (conformance to +/-3 Sigma)

Table 1

Model	URL	LRL	Min Span	Maximum Turndown Ratio	Reference Accuracy ^{1,2} (% Span)
STR82D	400 in H ₂ O (1000 mbar)	-400 in H ₂ O (-1000 mbar)	4 in H ₂ O (10 mbar)	100:1	0.0375
STR83D	100 psid (7.0 bar)	-100 psi (-7.0 bar)	1 in psi (0.07 bar)		
STR84G	500 psi (35 bar)	-14.7 (-1.0 bar)	5 psi (0.35 bar)		
STR87G	3000 psi (210 bar)	-14.7 psi (-1.0 bar)	30 psi (2.1 bar)		
STR84A	500 psia (35 bar)	0 psia (0 bar)	5 psia (0.35 bara)		

Zero and span may be set anywhere within the listed (URL/LRL) range limits.

Accuracy at Specified Span, Temperature and Static Pressure: (conformance to +/-3 Sigma)

Table 2

	Model	URL	Accuracy ^{1,2} (% of Span)			Combined Zero & Span Temperature Effect ³ (% Span/28°C (50°F))			
			Reference Turndown	A	B	C (see URL units)	D	E	F (see URL units)
Standard Accuracy	STR82D	400 in H ₂ O (1000mbar)	8:1	0.005	0.0325	50 (125)	0.175	1.000	200 (500)
	STR83D	100 psid (7.0 bar)	3.33:1			30 (2.1)	0.025	0.280	30 (2.1)
	STR84G	500 psi (35 bar)	25:1			20 (1.4)			
	STR87G	3000 psi (210 bar)	10:1			300 (21)			
	STR84A	500 psia (35 bara)	25:1			20 (1.4)			
Turn Down Effect						Temp Effect			
$\pm [A + B] \text{ if } Span \geq C$						$\pm [D + E \left(\frac{F}{Span}\right)]$			
$\pm \left[A + B \left(\frac{C}{Span}\right) \right] \text{ if } Span < C$									

Total Performance (% of Span):

Total Performance = _____ **+/- $\sqrt{(\text{Accuracy})^2 + (\text{Temp Effect})^2}$**

Total Performance Examples: (standard accuracy, 5:1 Turndown, up to 50°F shift)

STR82D @ 80 inH₂O: 2.68% of span

STR83D @ 20 psid: 0.45% of span

Typical Calibration Frequency:

Calibration verification is recommended every four (4) years.

Notes:

1. Terminal based Accuracy – Includes combined effects of linearity, hysteresis and repeatability. Analog output adds 0.005% of span.
2. For zero based spans and reference conditions of 25°C (77°F). 0 psi static pressure for DP, >= 0 psia for GP, 10 to 55% R.H, and 316 Stainless Steel barrier diaphragms.
3. Specification applies to transmitter with 2 balanced remote seals. Apply a 1.5 factor for temperature effect for capillary lengths greater than 10 feet.

Operating Conditions – All Models

Parameter	Reference Condition (at zero static)		Rated Condition		Operative Limits		Transportation and Storage																	
	°C	°F	°C	°F	°C	°F	°C	°F																
Ambient Temperature ¹	25±1	77±2	-	-	-	-	-55 to 90	-67 to 194																
Humidity %RH	10 to 55		0 to 100		0 to 100		0 to 100																	
Vac Region - Min Pressure mmHg absolute	Atmospheric (See Figure 4 for vacuum limitation)																							
Supply Voltage, Current, and Load Resistance	HART: 10.8 to 42.4 VDC at terminals (IS versions limited to 30 VDC) 0 to 1,440 ohms DE: 15 to 49.3VDC at terminals (IS versions limited to 30VDC), 0 to 1,200 ohms (as shown in Figure 2). FOUNDATION Fieldbus: 9.0 to 32.0 VDC at terminals, steady state current: 17.6mA, software download current: 27.4mA																							
Maximum Allowable Working Pressure (MAWP) ² <small>(ST 800 products are rated to Maximum Allowable Working Pressure. MAWP depends on Approval Agency and transmitter materials of construction.)</small>	MAWP is minimum of Body Rating or Seal Rating (See Model Selection Guide for Seal) <table border="1" style="width:100%; border-collapse: collapse;"> <thead> <tr> <th>Body</th> <th>MAWP</th> </tr> </thead> <tbody> <tr> <td>STR82D</td> <td>2,500 psig (172 bar) Bolted Process Heads</td> </tr> <tr> <td>STR83D</td> <td>2,500 psig (172 bar) Bolted Process Heads</td> </tr> <tr> <td>STR82D</td> <td>1,450 psig (100 bar) All Welded Process</td> </tr> <tr> <td>STR83D</td> <td>1,450 psig (100 bar) All Welded Process</td> </tr> <tr> <td>STR84G</td> <td>500 psig (35 bar)</td> </tr> <tr> <td>STR87G</td> <td>3,000 psig (210 bar)</td> </tr> <tr> <td>STR84A</td> <td>500 psia (35 bara)</td> </tr> </tbody> </table>								Body	MAWP	STR82D	2,500 psig (172 bar) Bolted Process Heads	STR83D	2,500 psig (172 bar) Bolted Process Heads	STR82D	1,450 psig (100 bar) All Welded Process	STR83D	1,450 psig (100 bar) All Welded Process	STR84G	500 psig (35 bar)	STR87G	3,000 psig (210 bar)	STR84A	500 psia (35 bara)
Body	MAWP																							
STR82D	2,500 psig (172 bar) Bolted Process Heads																							
STR83D	2,500 psig (172 bar) Bolted Process Heads																							
STR82D	1,450 psig (100 bar) All Welded Process																							
STR83D	1,450 psig (100 bar) All Welded Process																							
STR84G	500 psig (35 bar)																							
STR87G	3,000 psig (210 bar)																							
STR84A	500 psia (35 bara)																							

¹ Ambient Temperature Limit is a function of Process Interface Temperature and fill fluid. (See Figure 3 and Figure 4)

LCD Display operating temperature -20°C to +70°C . Storage temperature -30°C to 80°C.

² Consult factory for MAWP of ST 800 transmitters with CRN approval.

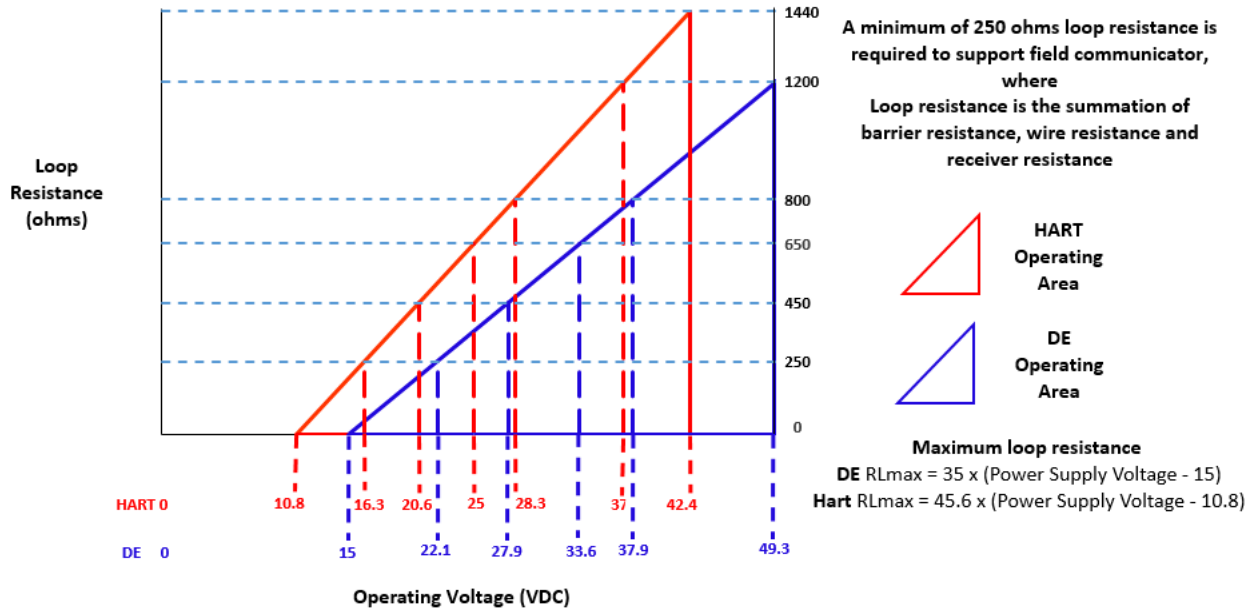

Figure 2 - Supply voltage and loop resistance

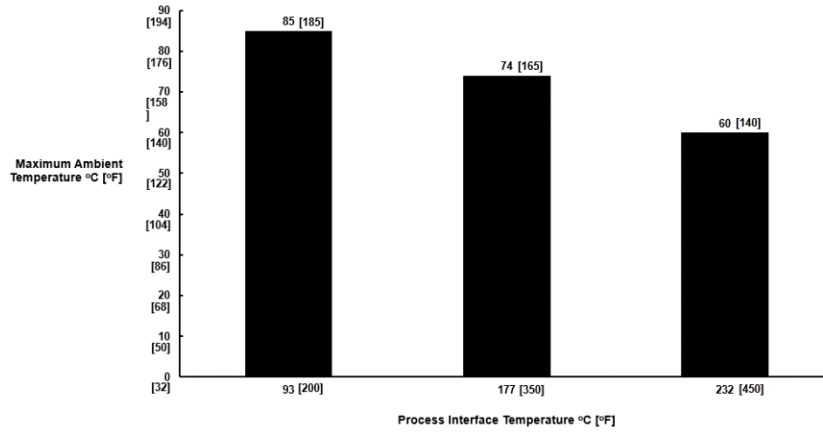

Figure 3 - Ambient temperature limits

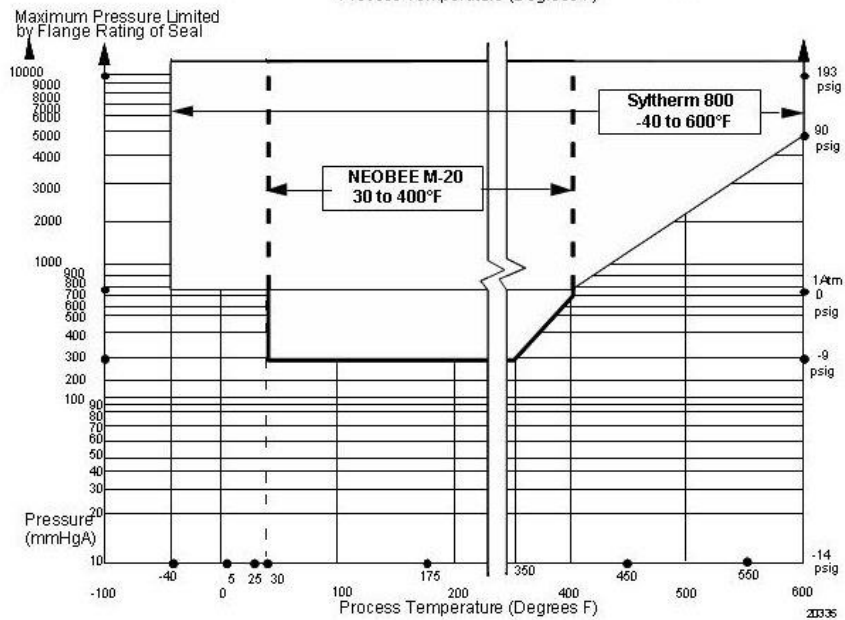
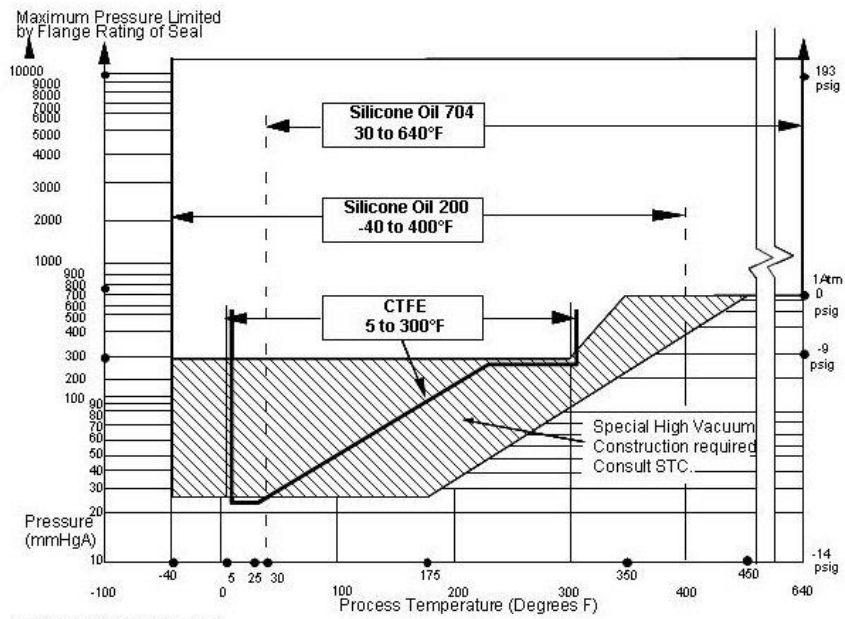

Figure 4 - STR800 Remote Seals operable limits for pressure vs. temperature

Performance Under Rated Conditions – All Models

Parameter	Description									
Analog Output Digital Communications	Two-wire, 4 to 20 mA (HART & DE Transmitters only) Honeywell DE, HART 7 protocol or FOUNDATION Fieldbus ITK 6.0.1 compliant All transmitters, irrespective of protocol have polarity insensitive connection									
HART & DE Output Failure Modes (NAMUR for DE Units requires selecting display and configuration buttons or factory configuration)	<table> <thead> <tr> <th></th> <th>Honeywell Standard</th> <th>NAMUR NE 43 Compliance</th> </tr> </thead> <tbody> <tr> <td>Normal Limits:</td> <td>3.8 – 20.8 mA</td> <td>3.8 – 20.5 mA</td> </tr> <tr> <td>Failure Mode:</td> <td>≤ 3.6 mA and ≥ 21.0 mA</td> <td>≤ 3.6 mA and ≥ 21.0 mA</td> </tr> </tbody> </table>		Honeywell Standard	NAMUR NE 43 Compliance	Normal Limits:	3.8 – 20.8 mA	3.8 – 20.5 mA	Failure Mode:	≤ 3.6 mA and ≥ 21.0 mA	≤ 3.6 mA and ≥ 21.0 mA
	Honeywell Standard	NAMUR NE 43 Compliance								
Normal Limits:	3.8 – 20.8 mA	3.8 – 20.5 mA								
Failure Mode:	≤ 3.6 mA and ≥ 21.0 mA	≤ 3.6 mA and ≥ 21.0 mA								
Supply Voltage Effect	0.005% span per volt									
Transmitter Turn on Time (includes power up & test algorithms)	HART or DE: 2.5 seconds Foundation Fieldbus: host dependent									
Damping Time Constant	HART: Adjustable from 0 to 32 seconds in 0.1 increments. Default: 0.50 seconds DE: Discrete values 0, .16, .32, .48, 1, 2, 4, 8, 16, 32 seconds. Default: 0.48 seconds									
Electromagnetic Compatibility	IEC 61326-3-1									
Lightning Protection Option	Leakage Current: 10uA max @ 42.4VDC 93C Impulse rating: 8/20us 5000A (>10 strikes) 10000A (1 strike min.) 10/1000us 200A (> 300 strikes)									

Materials Specifications (see Model Selection Guide for availability/restrictions with various models)

Parameter	Description
Process Interface	See Model Selection Guide for Material Options for desired seal type
Seal Barrier Diaphragm	316L Stainless Steel, Monel®, Hastelloy® C, Tantalum
Seal Gasket Materials	Klinger C-4401 (non-asbestos), Grafoil®, Teflon®, Gylon 3510®
Mounting Bracket	Carbon Steel (Zinc-Chromate plated) or 304 Stainless Steel or 316 Stainless Steel
Fill Fluid (Meter Body)	Silicone 200 S.G. @ 25°C = 0.94 CTFE (Chlorotrifluoroethylene) S.G. @ 25°C = 1.89 Silicone 704 S.G. @ 25°C = 1.07 NEOBEE M-20® S.G. @ 25°C = 0.93
Fill Fluid (Secondary)	Silicone Oil 200 S.G. @ 25°C = 0.94 CTFE (Chlorotrifluoroethylene) S.G. @ 25°C = 1.89 Silicone Oil 704 S.G. @ 25°C = 1.07 Syltherm 800® S.G. @ 25°C = 0.90 NEOBEE M-20® S.G. @ 25°C = 0.93
Electronic Housing	Pure Polyester Powder Coated Low Copper (<0.4%)-Aluminum. Meets NEMA 4X, IP66, & P67. All stainless steel housing is optional
Capillary Tubing	Material: Armored Stainless Steel or PVC Coated Armored Stainless Steel Length: 5, 10, 15, 20, 25, and 35 feet (1.5, 3, 4.6, 6.1, 7.5, and 10.7 meters) A 2 inch (51 millimeter) S.S. close-coupled nipple is also available. See Model Selection Guide Note: The minimum span is the higher of the higher of the value from the table above or the value defined under the Performance Conditions for the range transmitter for guide to maximum capillary length vs. diaphragm diameter
Wiring	Accepts up to 16 AWG (1.5 mm diameter)
Mounting	See
Dimensions	Transmitter: See Figure 7 and Figure 8. Seal: See Figure 9 through Figure 17
Net Weight	Transmitter: 8.3 pounds (3.8 Kg). With Aluminum Housing. Total weight is dependent on seal

NOTE: Pressure transmitters that are part of safety equipment for the protection of piping (systems) or vessel(s) from exceeding allowable pressure limits, (equipment with safety functions in accordance with Pressure Equipment Directive 97/23/EC article 1, 2.1.3), require separate examination.

Minimum recommended span for STR82D and STR83D Transmitter with two Remote Seals

Diaphragm Size (Inches)	Capillary Length (Feet)						Maximum Capillary Length (Feet)
	5	10	15	20	25	35	
2.4	7.2 psi						5
2.9	3.6 psi	4.5 psi	5.4 psi	6.3 psi			20
3.5	0.6 psi	0.7 psi	0.9 psi	1.0 psi	1.2 psi	1.4 psi	35
4.1	0.4 psi	0.5 psi	0.6 psi	0.8 psi	0.9 psi	1.1 psi	35

Minimum recommended span for STR82D and STR83D Transmitter with one Remote Seal

Diaphragm Size (Inches)	Direct Mount	Capillary Length (Feet)						Maximum Capillary Length (Feet)
		5	10	15	20	25	35	
2.4	20 psi	30 psi						5
2.9	10 psi	15 psi	20 psi	25 psi	30 psi			20
3.5	1.8 psi	2.9 psi	3.6 psi	4.3 psi	5.0 psi	5.8 psi	7.2 psi	35
4.1	1.4 psi	2.2 psi	2.9 psi	3.6 psi	4.3 psi	5.0 psi	5.8 psi	35

Minimum recommended span for STR84G, STR84A and STR87G Transmitter

Diaphragm Size (Inches)	Direct Mount	Capillary Length (Feet)						Maximum Capillary Length (Feet)
		5	10	15	20	25	35	
1.9	25 psi	30 psi	40 psi	50 psi				15
2.4	10 psi	15 psi	20 psi	25 psi	30 psi	35 psi	50 psi	35
2.9	8 psi	9 psi	10 psi	11 psi	12 psi	13 psi	15 psi	35
3.5	5 psi	5 psi	5 psi	5 psi	5 psi	6 psi	8 psi	35
4.1	5 psi	5 psi	5 psi	5 psi	5 psi	6 psi	8 psi	35

Note: The minimum span is the higher of the higher of the value from the table above or the value defined under the Performance Conditions for the range transmitter

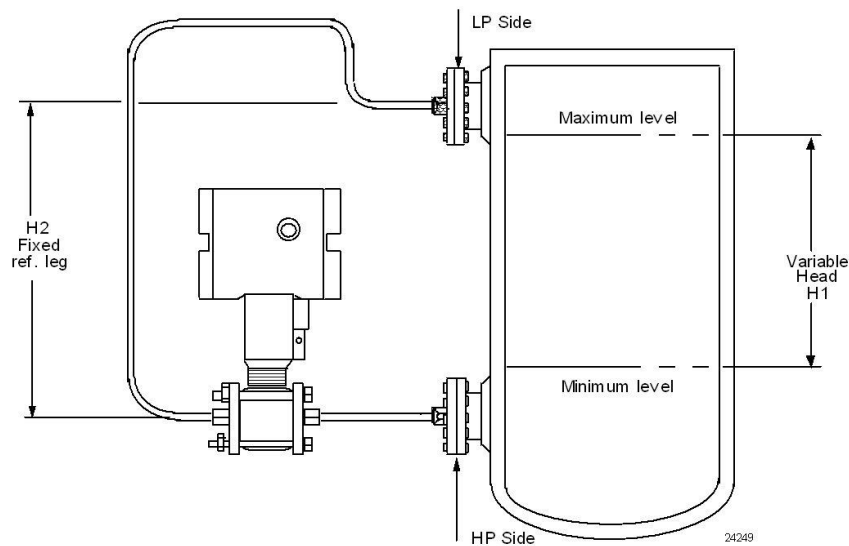

NOTE: Lower flange seal should not be mounted over 22 feet below or above the transmitter for silicone fill fluid (11 feet for CTFE fill fluid) with tank at one atmosphere. The combination of tank vacuum and high pressure capillary head effect should not exceed 9 psi vacuum (300 mmHg absolute).

Figure 5 - Typical Maximum capillary length and diaphragm size chart

Reference Dimensions Horizontal Mounting

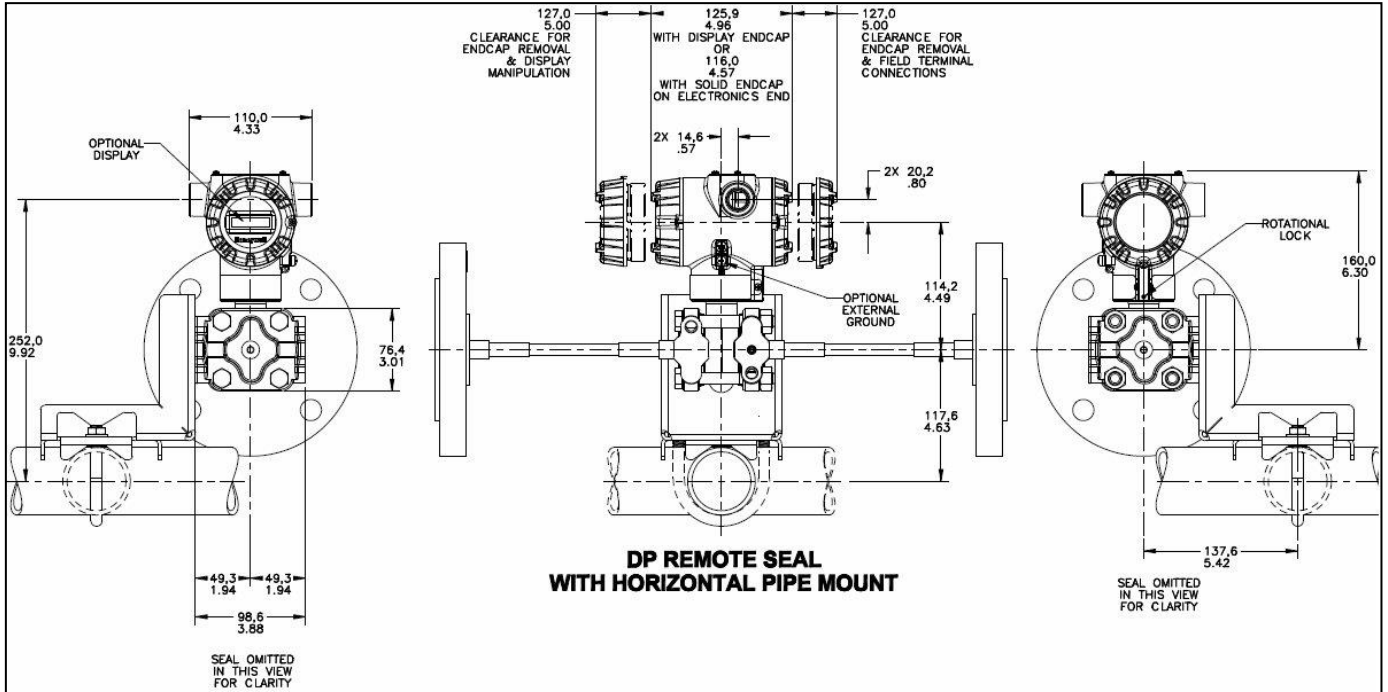
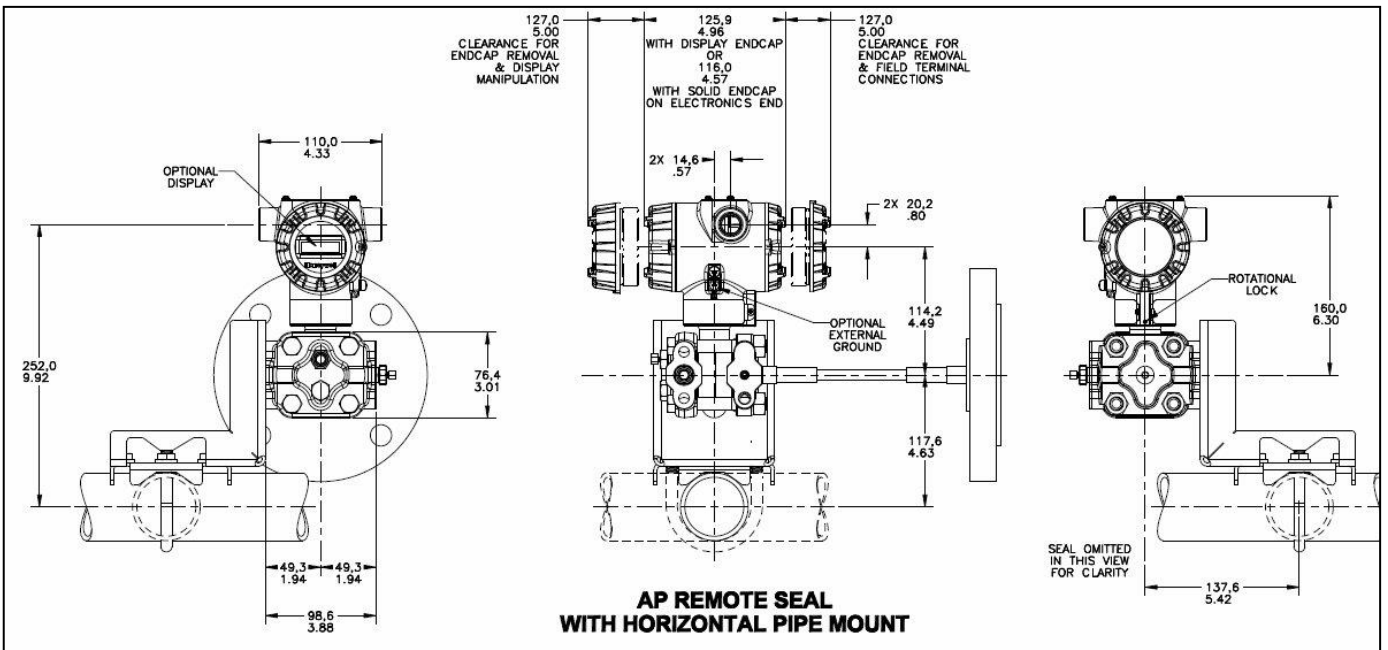

Figure 6 - STR800 transmitter with remote diaphragm seals shown mounted on a tank



Reference Dimensions Horizontal Mounting (cont'd)

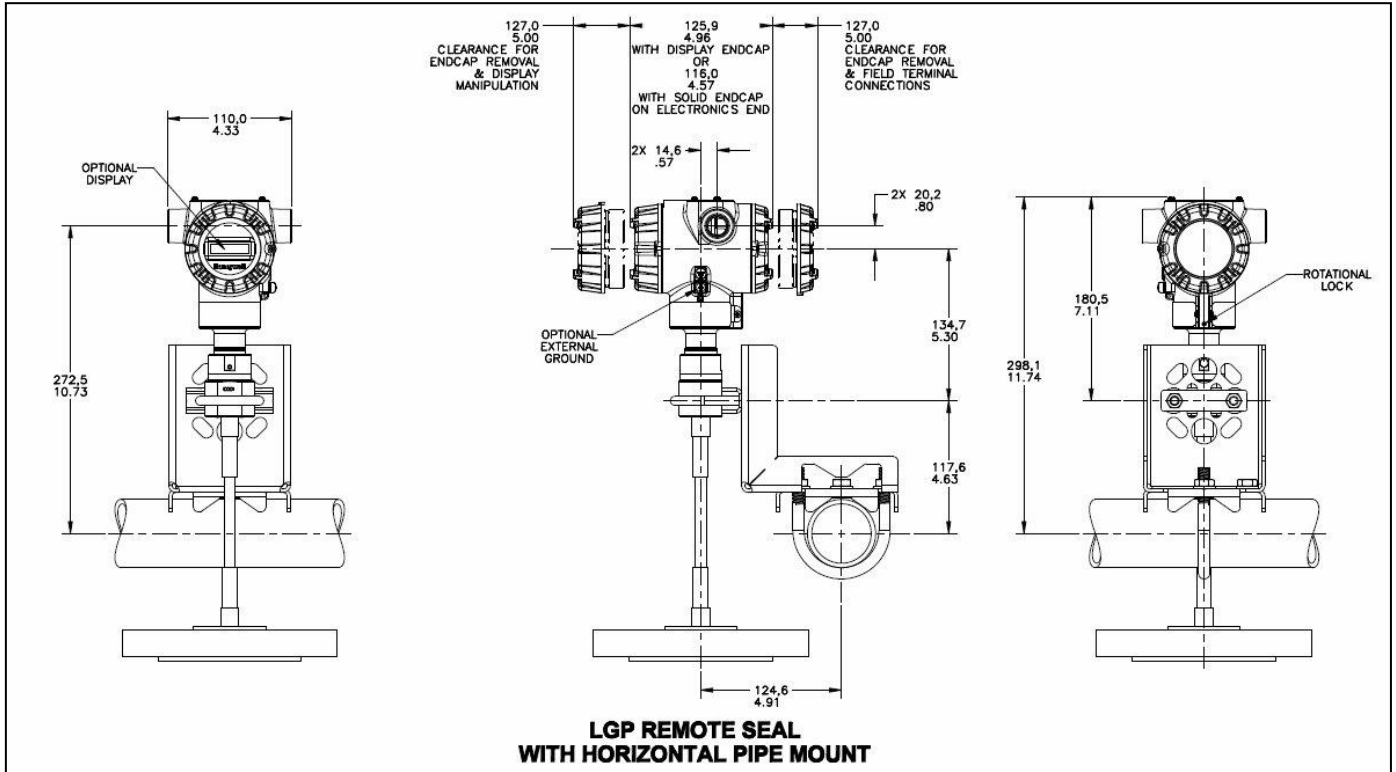
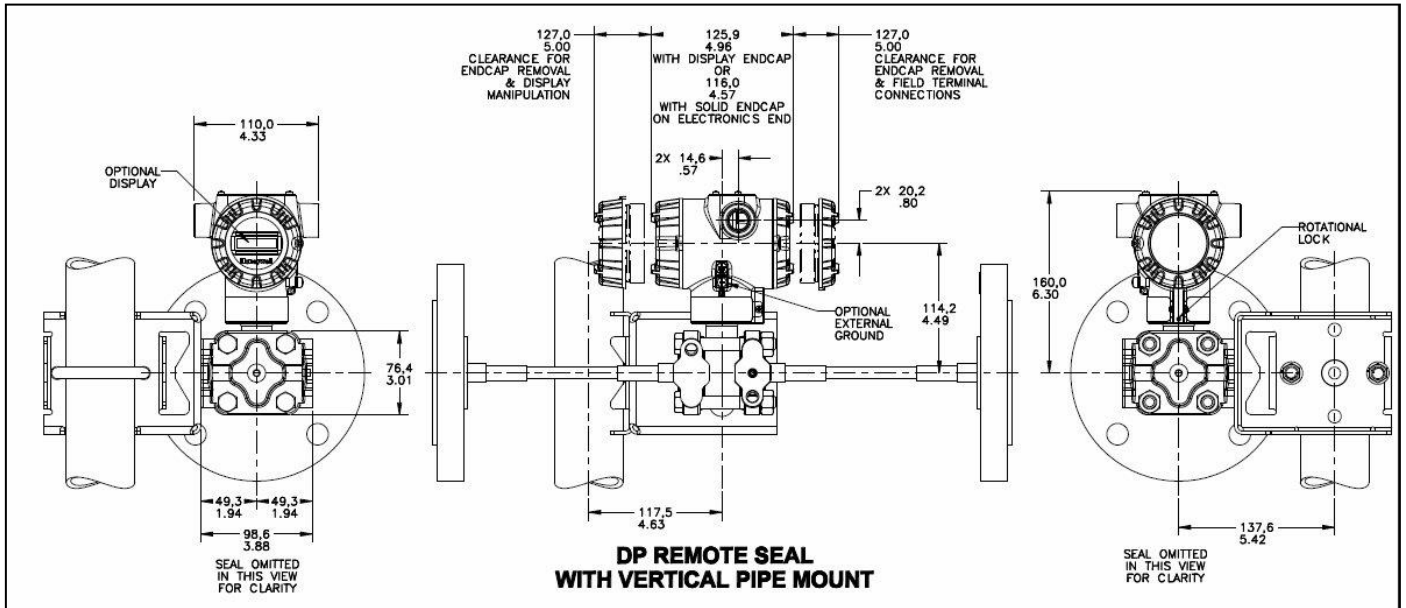

Figure 7 - Approximate horizontal mounting dimensions for Remote Seal Transmitter

Reference Dimensions Vertical Mounting



Reference Dimensions Vertical Mounting (cont'd)

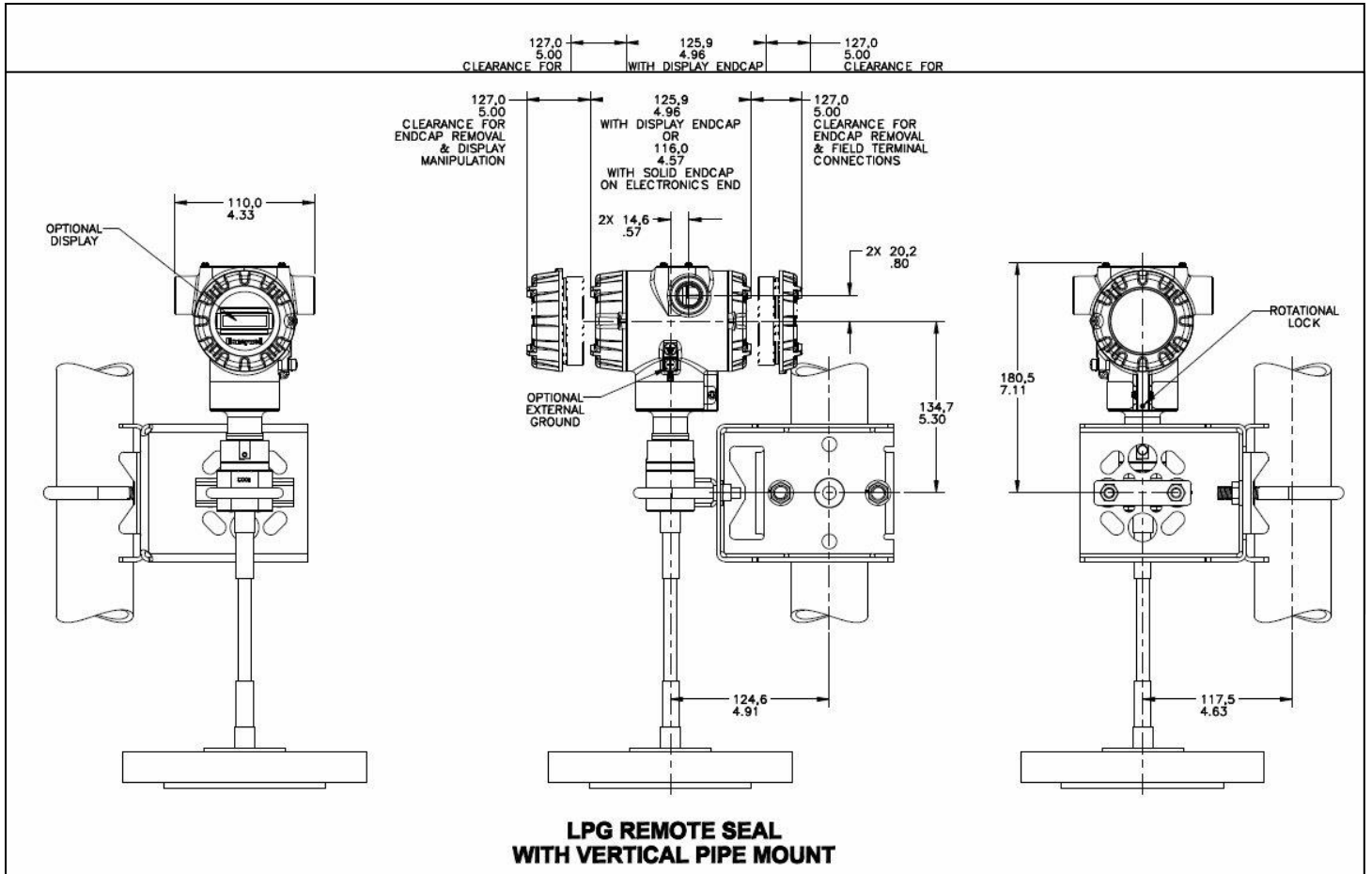
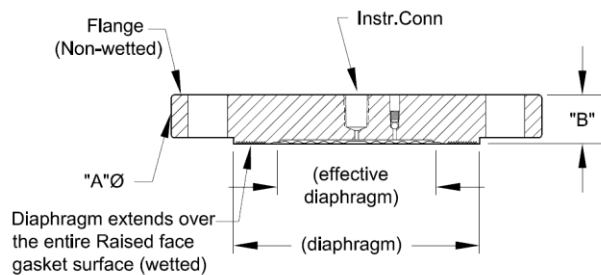

Figure 8 - Approximate vertical mounting dimensions for Remote Seal Transmitter

Reference Dimensions (cont'd)

Flush Flanged Seal Dimensions

Type	ANSI/DIN Rating	Flange Material	Wetted Materials		Construction See figure	Dimensions	
			Diaphragm	Body		A	B
Flush Flanged Seal	3" Class 150#	CS	SS	SS	D	7.5	1.37
			Hastelloy C	SS	C		
			Hastelloy C	Hastelloy C	D		
			Monel	Monel	D		
			Tantalum	SS	C		
		SS	N/A	B			
	SS	Hastelloy C	SS	A	7.50	0.94	
		Hastelloy C	Hastelloy C	D			
		Monel	Monel	D			
		Tantalum	SS	C			
		SS	SS	D			
	3" Class 300#	CS	Hastelloy C	SS	C	8.25	1.58
			Hastelloy C	Hastelloy C	D		
			Monel	Monel	D		
			Tantalum	SS	C		
			SS	N/A	B		
		SS	Hastelloy C	SS	A	8.25	1.12
	Hastelloy C		Hastelloy C	D			
	Monel		Monel	D			
	Tantalum		SS	C			
SS	SS		D				
3" Class 600#	CS	Hastelloy C	SS	C	8.25	1.75	
		Hastelloy C	Hastelloy C	D			
		Monel	Monel	D			
		Tantalum	SS	C			
		SS	N/A	B			
	SS	Hastelloy C	SS	A	8.25	1.5	
Hastelloy C		Hastelloy C	D				
Monel		Monel	D				
Tantalum		SS	C				
SS		SS	D				
DN80-PN40	CS	Hastelloy C	SS	C	7.87	1.32	
		Hastelloy C	Hastelloy C	D			
		Monel	Monel	D			
		Tantalum	SS	C			
		SS	N/A	B			
	SS	Hastelloy C	SS	A	7.87	0.94	
Hastelloy C		Hastelloy C	D				
Monel		Monel	D				
Tantalum		SS	C				
SS		SS	D				



Configuration "HS"

Figure A

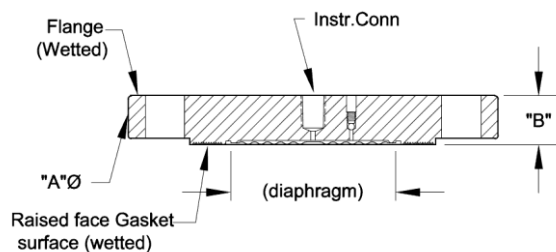

Configuration "HT"

Figure B

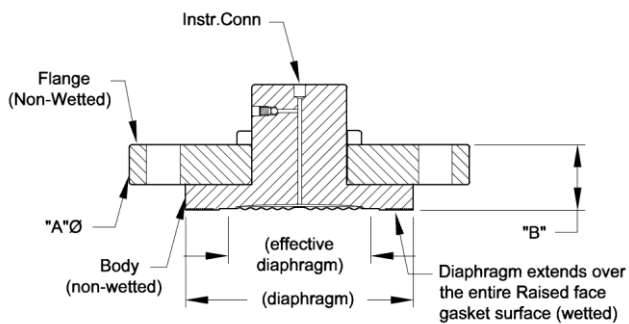

Configuration "IS"

Figure C

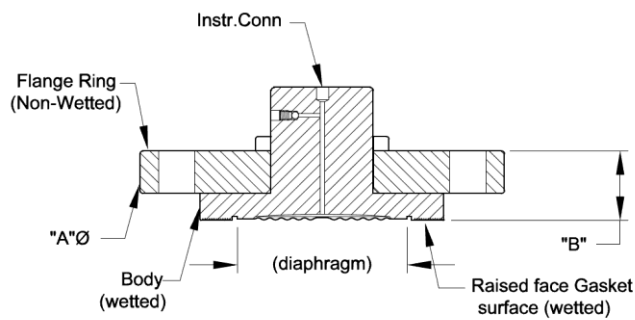

Configuration "IT"

Figure D

Figure 9 - Seal Dimensions (Flush Flanged)

Reference Dimensions (cont'd)

Flush Flanged Seal with Lower

Type	ANSI/DIN Rating	Size	Dimension	2.4" Diaph. Dia. (in.)	2.9" Diaph. Dia. (in.)	4.1" Diaph. Dia. (in.)
Flush Flanged Seal with Lower	Class 150#	1/2"	A	3.50	4.00	5.25
			B0	1.72	1.72	1.84
			B1	1.72	1.72	1.84
			B2	2.22	2.22	2.34
		1"	B0	4.25	4.00	5.25
			B1	1.12	1.72	1.84
			B2	1.62	1.72	1.84
			B2	1.99	1.72	2.34
		1-1/2"	B0	5.00	5.00	5.25
			B1	2.50	2.50	1.78
			B2	3.00	3.00	2.12
			B2	3.50	3.40	2.12
	2"	A	6.00	6.00	6.00	
		B0	2.50	2.50	2.12	
		B1	3.00	3.00	2.12	
		B2	3.50	3.40	2.12	
	3"	A	7.50	7.50	7.50	
		B0	2.58	2.88	2.60	
		B1	2.88	2.88	3.00	
		B2	3.50	3.40	3.40	
	Class 300#	1"	A	4.88	4.00	5.25
			B0	2.50	1.72	1.88
			B1	3.00	1.72	2.12
			B2	3.50	2.22	2.12
1-1/2"		A	6.12	6.12	5.25	
		B0	2.50	2.50	2.12	
		B1	3.00	3.00	2.12	
		B2	3.50	3.40	2.12	
2"		A	6.50	6.50	6.50	
		B0	2.50	2.50	2.70	
		B1	3.00	3.00	3.00	
		B2	3.50	3.40	3.50	
3"	A	8.25	8.25	8.25		
	B0	3.48	3.48	3.20		
	B1	3.48	3.48	3.60		
	B2	4.10	4.00	4.00		
Class 600#	1"	A	4.88	4.50	5.25	
		B0	2.50	2.15	2.26	
		B1	3.00	2.15	2.26	
		B2	3.50	2.40	2.50	
	1-1/2"	A	6.12	6.12	5.25	
		B0	2.50	1.53	2.50	
		B1	3.00	2.09	3.00	
		B2	3.50	2.49	3.50	
	2"	A	6.50	6.50	6.50	
		B0	3.10	3.10	3.30	
		B1	3.60	3.60	3.60	
		B2	4.10	4.00	4.10	
3"	A	8.25	8.25	8.25		
	B0	3.48	3.48	3.20		
	B1	3.48	3.48	3.60		
	B2	4.10	4.00	4.00		

B0 Without Flush
 B1 B Dimension with 1/4 NPT Flushing Connection
 B2 B Dimension with 1/2 NPT Flushing Connection

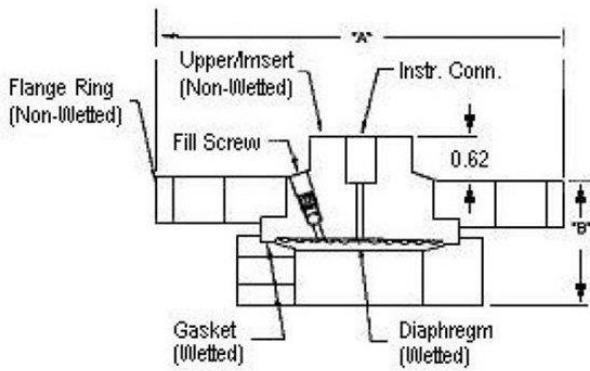

Flush Flanged Seal with Lower

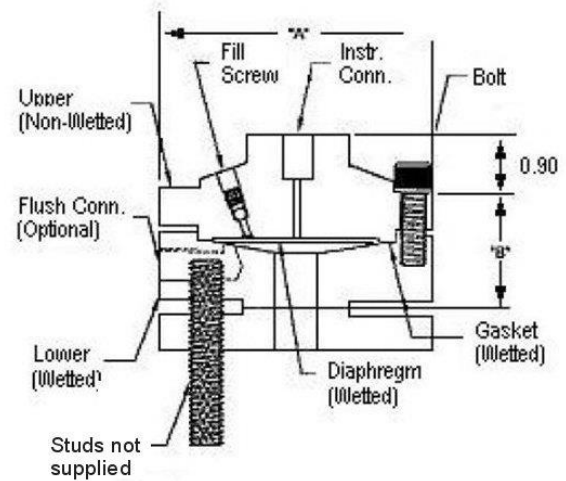

Flush Flanged Seal with Lower

Note: 0.90 dimension is 0.70 for 4.1" Dia Diaphragm

Figure 10 - Seal Dimension (Flush Flanged)

Reference Dimensions (cont'd)

Flanged Seal with Extended Diaphragm

Type	ANSI/DIN Rating	Dimension	2.8" Diaphragm Dia. (in.)	3.5" Diaphragm Dia. (in.)
Flanged Seal with Extended Diaphragm	3" Class 150#	A	7.50	-
		B	0.94	-
		C	2.80	-
	3" Class 300#	A	8.25	-
		B	1.12	-
		C	2.80	-
	DIN DN80-PN40	A	7.87	-
		B	0.94	-
		C	2.80	-
	4" Class 150#	A	-	9.00
		B	-	0.94
		C	-	3.70
4" Class 300#	A	-	10.00	
	B	-	1.25	
	C	-	3.70	
DIN DN100-PN40	A	-	9.25	
	B	-	0.94	
	C	-	3.70	

Designed to meet with schedule 40 pipe

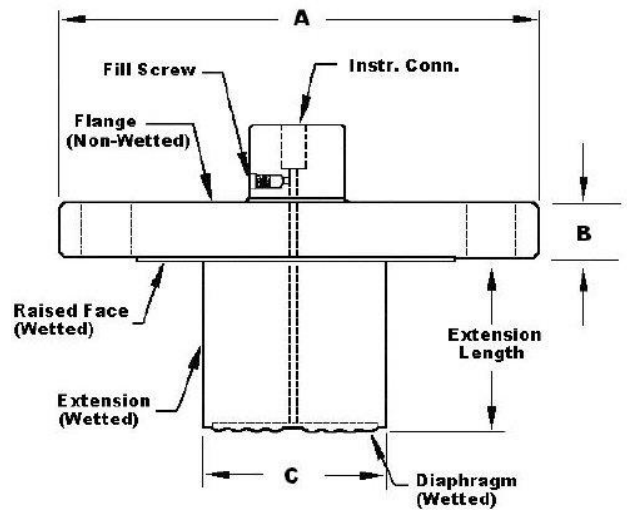

Figure 11 - Seal Dimensions (Extended Diaphragms)

Pancake Seal

Type	ANSI/DIN	Dimension	3.5" Diaph. (in.)
Pancake Seal	Class 150#, 300#, 600# DN80-PN40	A	5.00
		B	1.08

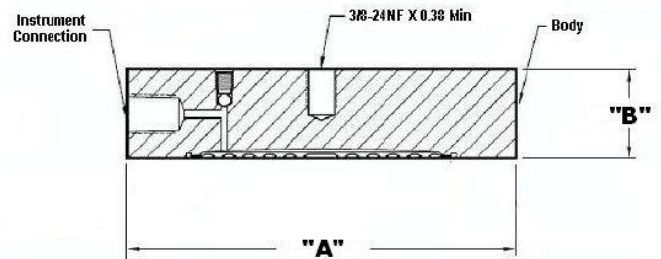

Figure 12 - Seal Dimensions (Pancake)

Chemical Tee "Taylor Wedge" Seal

Type	Size	Dimension	3.5" Diaph. (in.)
Chemical Tee "Taylor Wedge" Seal	750 psi	A	5.00
		B	0.50

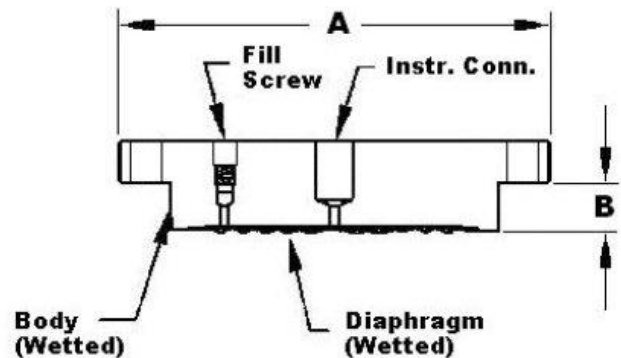

Figure 13 - Seal Dimensions (Chemical TEE "Taylor Wedge" Seals)

Seal with Threaded Process Connection

Type	Size	Dimension	2.4"	2.9"	4.1"
			Diaphragm Dia. (in.)	Diaphragm Dia. (in.)	Diaphragm Dia. (in.)
Threaded Process Conn. Seal	1/4" or 1/2"	A	3.50	4.00	5.25
		B0	1.88	1.88	1.79
		B1	1.88	1.88	1.79
	3/4" or 1"	A	3.50	4.00	5.25
		B0	1.88	1.88	1.79
		B1	1.88	1.88	1.79
		B2	8.25	2.18	2.14

B0 Without Flush
 B1 B Dimension with 1/4 NPT Flushing Connection
 B2 B dimension with 1/2 NPT Flushing Connection

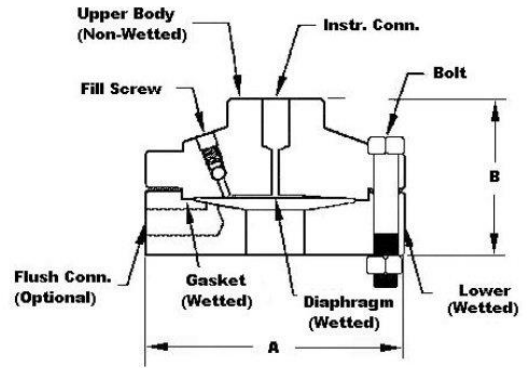

Figure 14 - Seal Dimensions (Threaded Process Connection Seals)

Sanitary Seal

Type	Size	Dimension	1.9"	2.4"	2.9"	4.1"
			Diaphragm Dia. (in.)	Diaphragm Dia. (in.)	Diaphragm Dia. (in.)	Diaphragm Dia. (in.)
Sanitary Seal	2"	A	2.50	-	-	-
		B	1.42	-	-	-
	2- 1/2"	A	-	3.00	-	-
		B	-	1.28	-	-
	3"	A	-	-	3.57	-
		B	-	-	1.38	-
4"	A	-	-	-	4.88	
	B	-	-	-	1.80	

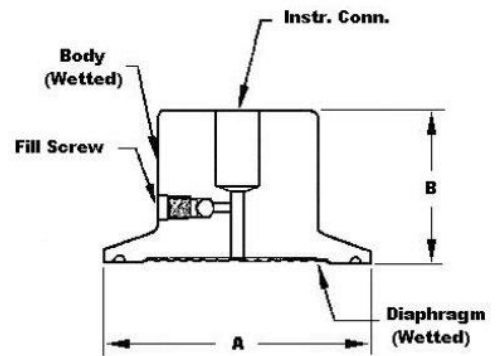

Figure 15- Seal Dimensions (Sanitary Seals)

Saddle Seal

Type	Size	Dimension	2.4" Diaph. (in.)
Saddle Seal	3"	A	3.50
		B	2.90
Saddle Seal	4" or larger	A	3.50
		B	3.04

Note: Specify 6 or 8 bolt pattern

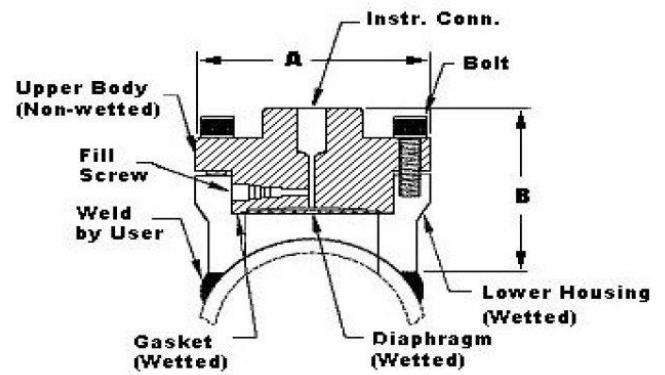

Figure 16 - Seal Dimensions (3" Saddle Seal)

Type	Size	Dimension	2.4" Diaph. (in.)
Saddle Seal	3"	A	3.50
		B	2.90
Saddle Seal	4" or larger	A	3.50
		B	3.04

Note: Specify 6 or 8 bolt pattern

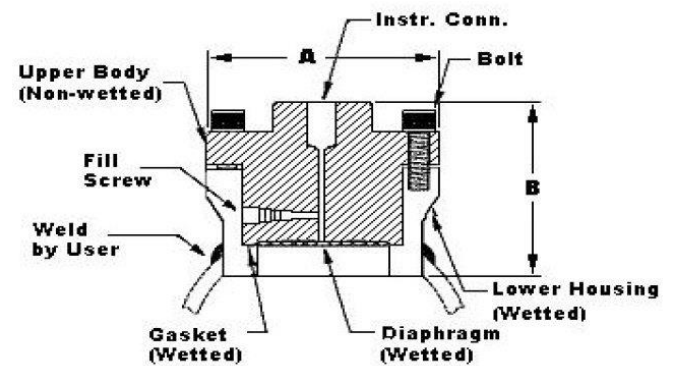

Figure 17 - Seal Dimensions (4" Saddle Seal)

Calibration Ring

Type	Size	Rating	Dimension	1/4 NPT	1/2 NPT
Calibration Ring	3"	150# / 800#	A	5.00	5.00
			B	1.00	1.50
			C	3.00	3.00

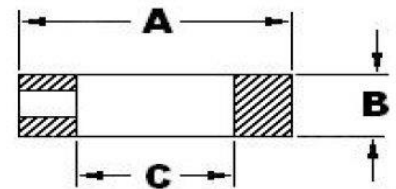

Figure 18 - Calibration Ring

Communications Protocols & Diagnostics

HART Protocol

Version: HART 7

Foundation Fieldbus (FF)

Available Function Blocks

Block Type	Qty	Execution Time
Resource	1	n/a
Transducer	1	n/a
Diagnostic	1	n/a
Analog Input	1*	30 ms
PID w/Autotune	1	45 ms
Integrator	1	30 ms
Signal Char (SC)	1	30 ms
LCD Display	1	n/a
Flow Block	1	30 ms
Input Selector	1	30 ms
Arithmetic	1	30 ms

* AI block may have two (2) additional instantiations.

All available function blocks adhere to FOUNDATION Fieldbus standards. PID blocks support ideal & robust PID algorithms with full implementation of Auto-tuning.

Link Active Scheduler

Transmitters can perform as a backup Link Active Scheduler and take over when the host is disconnected. Acting as a LAS, the device ensures scheduled data transfers typically used for the regular, cyclic transfer of control loop data between devices on the Fieldbus.

Number of Devices/Segment

Entity IS model: 6 devices/segment

Schedule Entries

18 maximum schedule entries

Number of VCR's: 24 max

Compliance Testing: Tested according to ITK 6.0.1

Software Download

Utilizes Class-3 of the Common Software Download procedure as per FF-883 which allows the field devices of any manufacturer to receive software upgrades from any host.

Honeywell Digitally Enhanced (DE)

DE is a Honeywell proprietary protocol which provides digital communications between Honeywell DE enabled field devices and Hosts.

Standard Diagnostics

ST 800 top level diagnostics are reported as either critical or non-critical and are readable via the DD/DTM/FDI tools or integral display. All critical diagnostics will appear on the Advanced and Standard integral displays, and some non-critical diagnostics will also appear on the Advanced integral display. Some of the diagnostics are listed below.

Critical Diagnostics

- Electronics Module Fault.
- Meter body Memory Corruption.
- Config Data Corruption.
- Electronics Module Diagnostics Failure.
- Meter body Critical Failure.
- Sensor Communication Timeout.

Non-Critical Diagnostics

- Electronics Module Fault.
- Display Failure.
- Electronics Module Comm Failure.
- Meter body Excess Correct.
- Sensor Over Temperature.
- Fixed Current Mode.
- PV Out of Range.
- No DAC Compensation.
- Tamper Attempt Alarm.

Refer to the product user manual for comprehensive list of diagnostics and details.









Other Certification Options

Materials

- NACE MRO175, MRO103, ISO15156

Hazardous Areal Certification

MSG CODE	AGENCY	TYPE OF PROTECTION	COMM. OPTION	ELECTRICAL PARAMETERS	AMBIENT TEMP (Ta)
A	FM Approvals™ USA	Explosionproof: Class I, Division 1, Groups A, B, C, D; Dust Ignition Proof: Class II, III, Division 1, Groups E, F, G; T6..T5 Class I, Zone 0/1, AEx db IIC T6..T5 Ga/Gb Class II, Zone 21, AEx tb IIIC T95° Db	All	Note 1	T5: -50 °C to 85°C T6: -50 °C to 65°C
		Intrinsically Safe: Class I, II, III, Division 1, Groups A, B, C, D, E, F, G: T4 Class I, Zone 0, AEx ia IIC T4 Ga FISCO Field Device (Only for FF Option) Ex ia IIC T4 Ga; Ex ic IIC T4 Gc	4-20 mA / DE/ HART	Note 2a	-50 °C to 70°C
		Nonincendive: Class I, Division 2, Groups A, B, C, D locations, T4 Class I, Zone 2, AEx nA IIC T4 Gc	Foundation Fieldbus	Note 2b	-50 °C to 70°C
		Nonincendive: Class I, Division 2, Groups A, B, C, D locations, T4 Class I, Zone 2, AEx nA IIC T4 Gc	4-20 mA / DE/ HART/ Foundation Fieldbus	Note 1	-50 °C to 85°C
		Enclosure: Type 4X/ IP66/ IP67	All	All	-
		STANDARDS: FM Class 3600:2011; FM Class 3610: 2010; FM Class 3611: 2004; FM Class 3615: 2006; FM Class 3616: 2011; FM Class 3810: 2005; ANSI/ISA 60079-0: 2013; ANSI/UL 60079-1: 2015; ANSI/UL 60079-11: 2014; ANSI/ISA 60079-15: 2012; ANSI/UL 60079-26: 2017; ANSI/UL 60079-31: 2015; ANSI/NEMA 250: 2003; ANSI/ IEC 60529: 2004			
B	Canadian Standards Association (CSA) USA and Canada	Explosion Proof: Class I, Division 1, Groups A, B, C, D; Class II, Division 1, Groups E, F, G; Class III, Division 1, T6..T5 Class I Zone 1 AEx db IIC T6..T5 Ga/Gb Ex db IIC T6..T5 Ga/Gb Zone 22 AEx tb IIIC T95° Db Ex tb IIIC T95° Db	All	Note 1	T5: -50°C TO 85°C T6: -50°C TO 65°C
		Intrinsically Safe: Class I, II, III, Division 1, Groups A, B, C, D; Class II, Division 1, Groups E, F, G; Class III, Division 1, T4 Class I Zone 0, AEx ia IIC T4 Ga Class I Zone 2, AEx ic IIC T4 Gc Ex ia IIC T4 Ga Ex ic IIC T4 Gc FISCO Field Device (Only for FF Option) Ex ia IIC T4 Ga; Ex ic IIC T4 Gc	4-20 mA / DE/ HART	Note 2	-50°C TO 70°C
		Nonincendive: Class I, Division 2, Groups A, B, C, D; Class II, Division 2, Groups F, G; Class III, Division 2, T4 Class I Zone 2 AEx nA IIC T4 Gc Ex nA IIC T4 Gc	Foundation Fieldbus	Note 2	-50°C TO 70°C
		Nonincendive: Class I, Division 2, Groups A, B, C, D; Class II, Division 2, Groups F, G; Class III, Division 2, T4 Class I Zone 2 AEx nA IIC T4 Gc Ex nA IIC T4 Gc	4-20 mA / DE/ HART/ Foundation Fieldbus	Note 1	-50°C to 85°C
		Enclosure: Type 4X/ IP66/ IP67	All	All	-

MSG CODE	AGENCY	TYPE OF PROTECTION	COMM. OPTION	ELECTRICAL PARAMETERS	AMBIENT TEMP (Ta)
		STANDARDS: CSA C22.2 No. 0-10; CSA C22.2 No. 94-M91; CSA C22.2 No. 25-1966; CSA C22.2 No. 30-M1986; CSA C22.2 No. 142-M1987; CSA C22.2 No. 157-92; CSA C22.2 No. 213-M1987; CSA-C22.2 No. 60529:05; CSA-C22.2 No. 60079-0:11; CSA-C22.2 No. 60079-1:11; CSA-C22.2 No. 60079-11:11; CSA-C22.2 No. 60079-15:12; CSA-C22.2 No. 60079-31:12; ISA 12.12.01-2010; ISA 60079-0: 2009; ISA 60079-11: 2011; ISA 60079-15: 2009; ISA 60079-26: 2008; ISA-60079-27:2007 (12.02.04)-2006 (R2011); UL 913 Ed. 6; UL 916:1998; ANSI/ISA-12.27.01-2011			
C	ATEX	Flameproof: SIRA 12ATEX2233X  II 1/2 G Ex db IIC T6..T5 Ga/Gb II 2 D Ex tb IIIC T95°C...T120°C Db	All	Note 1	T5: -50°C TO 85°C T6: -50°C TO 65°C
		Intrinsically Safe: SIRA 12ATEX2233X  II 1 G Ex ia IIC T4 Ga II 2 D Ex ia IIIC T125°C Db FISCO Field Device (Only for FF Option) II 1 G Ex ia IIC T4 Ga	4-20 mA / DE/ HART	Note 2	-50°C TO 70°C
		Zone 2, Increase Safety: SIRA 12ATEX4234X  II 3 G Ex ec IIC T4 Gc	4-20 mA / DE/ HART/	Note 1	-50°C TO 85°C
		Zone 2, Intrinsically Safe: SIRA 12ATEX4234X  II 3 G Ex ic IIC T4 Gc FISCO Field Device (Only for FF Option) II 3 G Ex ic IIC T4 Gc	4-20 mA / DE/ HART/ Foundation Fieldbus	Note 2	-50°C TO 85°C
		Enclosure: IP66/ IP67	All	All	-
		STANDARDS: EN 60079-0: 2018; EN 60079-1: 2014; EN 60079-7: 2015; EN 60079-11: 2012; EN 60079-26: 2015; EN 60079-31: 2014			
	UKEX	Flameproof: CSAE 22UKEX1021X  II 1/2 G Ex db IIC T6..T5 Ga/Gb II 2 D Ex tb IIIC T95°C...T120°C Db	All	Note 1	T5: -50°C TO 85°C T6: -50°C TO 65°C
		Intrinsically Safe: CSAE 22UKEX1021X  II 1 G Ex ia IIC T4 Ga II 2 D Ex ia IIIC T125°C Db FISCO Field Device (Only for FF Option) II 1 G Ex ia IIC T4 Ga	4-20 mA / DE/ HART	Note 2	-50°C TO 70°C
		Zone 2, Increase Safety: CSAE 22UKEX1008X  II 3 G Ex ec IIC T4 Gc	4-20 mA / DE/ HART/	Note 1	-50°C TO 85°C
		Zone 2, Intrinsically Safe: CSAE 22UKEX1008X  II 3 G Ex ic IIC T4 Gc FISCO Field Device (Only for FF Option) II 3 G Ex ic IIC T4 Gc	4-20 mA / DE/ HART/ Foundation Fieldbus	Note 2	-50°C TO 85°C
		Enclosure: IP66/ IP67	All	All	-

MSG CODE	AGENCY	TYPE OF PROTECTION	COMM. OPTION	ELECTRICAL PARAMETERS	AMBIENT TEMP (Ta)
		STANDARDS: EN 60079-0: 2018; EN 60079-1: 2014; EN 60079-7: 2015; EN 60079-11: 2012; EN 60079-26: 2015; EN 60079-31: 2014			
D	IECEX World	Flameproof: IECEx SIR 12.0100X Ex db IIC T6..T5 Ga/Gb Ex tb IIIC T95°C...T120°C Db	All	Note 1	T5: -50°C TO 85°C T6: -50°C TO 65°C
		Intrinsically Safe: IECEx SIR 12.0100X Ex ia IIC T4 Ga Ex ia IIIC T125°C Db FISCO Field Device (Only for FF Option) Ex ia IIC T4 Ga; Ex ic IIC T4 Gc	4-20 mA / DE/ HART	Note 2	-50°C TO 70°C
			Foundation Fieldbus	Note 2	-50°C TO 70°C
		Zone 2, Increase Safety: IECEx SIR 12.0100X Ex ec IIC T4 Gc	4-20 mA / DE/ HART/ Foundation Fieldbus	Note 1	-50°C TO 85°C
		Zone 2, Intrinsically Safe: IECEx SIR 12.0100X Ex ic IIC T4 Gc FISCO Field Device (Only for FF Option) Ex ic IIC T4 Gc	4-20 mA / DE/ HART/ Foundation Fieldbus	Note 2	-50°C TO 85°C
		Enclosure: IP66/ IP67	All	All	-
STANDARDS: IEC 60079-0: 2017; IEC 60079-1: 2014; IEC 60079-7: 2017; IEC 60079-11: 2011; IEC 60079-26: 2014; IEC 60079-31: 2013					

E	SAEx South Africa	Flameproof : Ex d IIC T6...T5 Ga/Gb Ex tb IIIC T95°C...T120°C Db	All	Note 1	T5: -50°C TO 85°C T6: -50°C TO 65°C
		Intrinsically Safe: Ex ia IIC Ga T4 FISCO Field Device (Only for FF Option) Ex ia IIC T4 Ga; Ex ic IIC T4 Gc	4-20 mA / DE/ HART	Note 2	-50°C TO 70°C
			Foundation Fieldbus	Note 2	-50°C TO 70°C
		Zone 2, Increase Safety: II 3 G Ex ec IIC T4 Gc	4-20 mA / DE/ HART/ Foundation Fieldbus	Note 1	-50°C TO 85°C
		Zone 2, Intrinsically Safe: Ex ic IIC T4 Gc FISCO Field Device (Only for FF Option) Ex ic IIC T4 Gc	4-20 mA / DE/ HART/ Foundation Fieldbus	Note 2	-50°C TO 85°C
	Enclosure: IP66/ IP67	All	All	-	
F	INMETRO Brazil	Flameproof: Ex db IIC T6..T5 Ga/Gb Ex tb IIIC T95°C...T120°C Db	All	Note 1	T5: -50°C TO 85°C T6: -50°C TO 65°C
		Intrinsically Safe: Ex ia IIC T4 Ga	4-20 mA / DE/ HART	Note 2a	-50°C TO 70°C
		FISCO Field Device (Only for FF Option) Ex ia IIC T4 Ga; Ex ic IIC T4 Gc	Foundation Fieldbus	Note 2b	-50°C TO 70°C
		Zone 2, Increase Safety: II 3 G Ex ec IIC T4 Gc	4-20 mA / DE/ HART/ Foundation Fieldbus	Note 1	-50°C TO 85°C
		Zone 2, Intrinsically Safe: Ex ic IIC T4 Gc FISCO Field Device (Only for FF Option) Ex ic IIC T4 Gc	4-20 mA / DE/ HART/ Foundation Fieldbus	Note 2	-50°C TO 85°C
		Enclosure : IP 66/67	All	All	-
G	NEPSI CHINA	Flameproof: Ex db IIC T6..T5 Ga/Gb Ex tb IIIC T 95°C Db	All	Note 1	T5: -50°C TO 85°C T6: -50°C TO 65°C
		Intrinsically Safe: Ex ia IIC T4 Ga	4-20 mA / DE/ HART	Note 2	-50°C TO 70°C
		FISCO Field Device (Only for FF Option) Ex ia IIC T4 Ga; Ex ic IIC T4 Gc	Foundation Fieldbus	Note 2	-50°C TO 70°C
		Zone 2, Increase Safety: II 3 G Ex ec IIC T4 Gc	4-20 mA / DE/ HART/ Foundation Fieldbus	Note 1	-50°C TO 85°C
		Zone 2, Intrinsically Safe: Ex ic IIC T4 Gc FISCO Field Device (Only for FF Option) Ex ic IIC T4 Gc	4-20 mA / DE/ HART/ Foundation Fieldbus	Note 2	-50°C TO 85°C
	Enclosure : IP 66/67	All	All	-	
H	KOSHA	Flameproof :	All	Note 1	T4: -50°C TO 85°C

	Korea	Ex d IIC T4, T5, T6 Ex tD A21 IP66/IP67 T95°C...T120°C			T5: -50°C TO 85°C T6: -50°C TO 65°C
		Intrinsically Safe: Ex ia IIC T4	4-20 mA / DE/ HART	Note 2	Ta= -50 °C to 70°C
			Foundation Fieldbus	Note 2	Ta= -50 °C to 70°C
Enclosure: IP66/ IP67		All	All	-	
I	EAC Russia, Belarus and Kazakhstan	Flameproof: Ga/Gb Ex d IIC T6..T5 Ex tb IIIC Db T 85°C	All	Note 1	T5: -50°C TO 85°C T6: -50°C TO 65°C
		Intrinsically Safe: Ga Ex ia IIC T4 X FISCO Field Device (Only for FF Option) Ga Ex ia IIC T4 X	4-20 mA / DE/ HART	Note 2	-50°C TO 70°C
			Foundation Fieldbus	Note 2	-50°C TO 70°C
		Zone 2, Non Sparking: 2 Ex nA IIC T4 Gc X	4-20 mA / DE/ HART/ Foundation Fieldbus	Note 1	-50°C TO 85°C
		Zone 2, Intrinsically Safe: Ga Ex ic IIC T4 X FISCO Field Device (Only for FF Option) 2 Ex ic IIC T4 Gc X	4-20 mA / DE/ HART/ Foundation Fieldbus	Note 2	-50°C TO 85°C
		Enclosure : IP 66/67		All	All
J	CCoE INDIA	Flameproof: Ex d IIC T6..T5 Ga/Gb	All	Note 1	T5: -50°C TO 85°C T6: -50°C TO 65°C
		Intrinsically Safe: Ex ia IIC T4 Ga FISCO Field Device (Only for FF Option) Ex ia IIC T4 Ga; Ex ic IIC T4 Gc	4-20 mA / DE/ HART	Note 2	-50°C TO 70°C
			Foundation Fieldbus	Note 2	-50°C TO 70°C
		Non Sparking Ex nA IIC T4 Gc	4-20 mA / DE/ HART/ Foundation Fieldbus	Note 1	-50°C TO 85°C
		Enclosure: IP66/ IP67		All	All
K	UATR UKRAINE	Flameproof: II 1/2 G Ex db IIC T6..T5 Ga/Gb II 2 D Ex tb IIIC T95°C...T120°C Db	All	Note 1	T5: -50°C TO 85°C T6: -50°C TO 65°C
		Intrinsically Safe: II 1 G Ex ia IIC T4 Ga FISCO Field Device (Only for FF Option) II 1 G Ex ia IIC T4 Ga	4-20 mA / DE/ HART	Note 2	-50°C TO 70°C
			Foundation Fieldbus	Note 2	-50°C TO 70°C
		Enclosure: IP66/ IP67		All	All

Notes:

1. Operating Parameters:

Voltage = 11 to 42 VDC

Current = 4-20 mA Normal

= 9 to 32 V (FF)

= 30 mA (FF)

2. Intrinsically Safe Entity Parameters

a. Analog / DE/ HART Entity Values:

Vmax = Ui = 30V Imax = li = 105mA Ci = 4.2nF Li = 984 uH Pi = 0.9W

Transmitter with Terminal Block Revision E or Later

Vmax = Ui = 30V Imax = li = 225mA Ci = 4.2nF Li = 0 Pi = 0.9W

Note : Transmitter with Terminal Block Revision E or later

The revision is on the label that is on the module. There will be two lines of text on the label:

- First is the Module Part #: 50049839-001 or 50049839-002
- Second line has the supplier information, along with the REVISION:

XXXXXXX-EXXXX, THE "X" is production related; THE POSITION of the "E" IS THE REVISION.

b. Foundation Fieldbus- Entity Values

Vmax = Ui = 30V Imax = li = 180mA Ci = 0nF Li = 984 uH Pi = 1W

Transmitter with Terminal Block Revision F or Later

Vmax = Ui = 30V Imax = li = 225mA Ci = 0nF Li = 0 Pi = 1 W

FISCO Field Device Imax = li = 380 mA Ci = 0nF Li = 0 Pi = 5.32 W

Vmax = Ui = 17.5V

Note : Transmitter with Terminal Block Revision F or later

The revision is on the label that is on the module. There will be two lines of text on the label:

- First is the Module Part #: 50049839-003 or 50049839-004
- Second line has the supplier information, along with the REVISION:

XXXXXXX-EXXXX, THE "X" is production related, THE POSITION of the "E" IS THE REVISION

Approval Certifications

Marine Certificates	This certificate defines the certifications covered for the SmartLine Pressure Transmitter family of products, including the SMV SmartLine Multivariable Transmitter. It represents the compilation of the five certificates Honeywell currently has covering the certification of these products into marine applications																	
	American Bureau of Shipping (ABS) - 2009 Steel Vessel Rules 1-1-4/3.7, 4-6-2/5.15, 4-8-3/13 & 13.5, 4-8-4/27.5.1, 4-9-7/13. Certificate number: 04-HS417416-PDA																	
	Bureau Veritas (BV) - Product Code: 389:1H. Certificate number: 12660/B0 BV																	
	Det Norske Veritas (DNV) - Location Classes: Temperature D, Humidity B, Vibration A, EMC B, Enclosure C. For salt spray exposure; enclosure of 316 SST or 2-part epoxy protection with 316 SST bolts to be applied. Certificate number: A-11476																	
	Korean Register of Shipping (KR) - Certificate number: LOX17743-AE001																	
	Lloyd's Register (LR) - Certificate number: 02/60001(E1) & (E2)																	
SIL 2/3 Certification	IEC 61508 SIL 2 for non-redundant use and SIL 3 for redundant use according to EXIDA and TÜV Nord Sys Tec GmbH & Co. KG under the following standards: IEC61508-1: 2010; IEC 61508-2: 2010; IEC61508-3: 2010																	
MEASUREMENT INSTRUMENTS DIRECTIVE (MID) 2004/ 22/ EC	<p>Certificate Issued by NMI Certin B.V. Mechanical Class: M3 Electromagnetic Environment: E3 Ambient Temperature Range: -25 °C to + 55 °C</p> <table border="1" style="width: 100%; border-collapse: collapse;"> <thead> <tr> <th style="width: 50%;">Unit</th> <th style="width: 50%;">Custom Calibration</th> </tr> </thead> <tbody> <tr> <td>STD820</td> <td>0 to 1000 mBar</td> </tr> <tr> <td>STD830</td> <td>0 to 7 Bar</td> </tr> <tr> <td>STA84L</td> <td>0 to 35 Bar A</td> </tr> <tr> <td>STG84L</td> <td>0 to 35 Bar</td> </tr> <tr> <td>STD870</td> <td>0 to 100 Bar</td> </tr> <tr> <td>STA87L</td> <td>0 to 100 Bar A</td> </tr> <tr> <td>STG87L</td> <td>0 to 100 Bar</td> </tr> </tbody> </table>		Unit	Custom Calibration	STD820	0 to 1000 mBar	STD830	0 to 7 Bar	STA84L	0 to 35 Bar A	STG84L	0 to 35 Bar	STD870	0 to 100 Bar	STA87L	0 to 100 Bar A	STG87L	0 to 100 Bar
Unit	Custom Calibration																	
STD820	0 to 1000 mBar																	
STD830	0 to 7 Bar																	
STA84L	0 to 35 Bar A																	
STG84L	0 to 35 Bar																	
STD870	0 to 100 Bar																	
STA87L	0 to 100 Bar A																	
STG87L	0 to 100 Bar																	

Application Data

Liquid Level: Closed Tank

Determine the minimum and maximum pressure differentials to be measured (Figure 19).

$$\begin{aligned} P_{\text{Min}} &= (SG_p \times a) - (SG_f \times d) \\ &= \text{LRV when HP at bottom of tank} \\ &= -\text{URV when LP at bottom of tank} \end{aligned}$$

$$\begin{aligned} P_{\text{Max}} &= (SG_p \times b) - (SG_f \times d) \\ &= \text{URV when HP at bottom of tank} \\ &= -\text{LRV when LP at bottom of tank} \end{aligned}$$

Where:

minimum level at 4mA
maximum level at 20 mA

a = distance between bottom tap and minimum level

b = distance between bottom tap and maximum level

d = distance between taps

SG_f = Specific Gravity of capillary fill fluid (See Page 6 "Material Specifications" for values.)

SG_p = Specific Gravity of process fluid

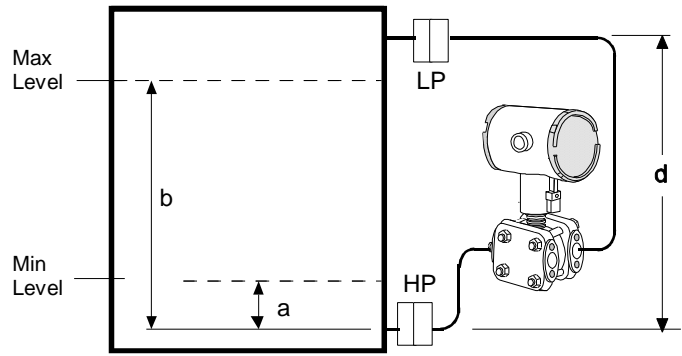

Transmitter above datum

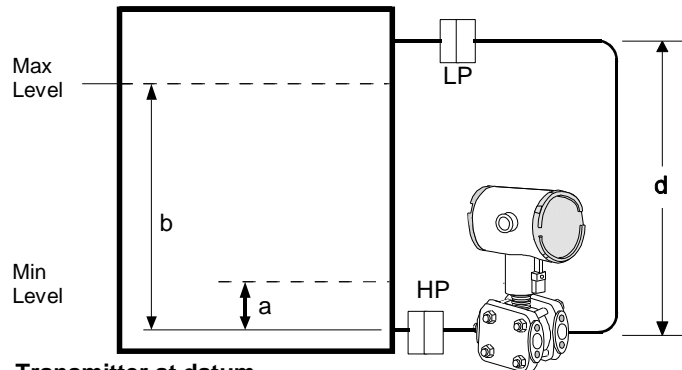

Transmitter at datum

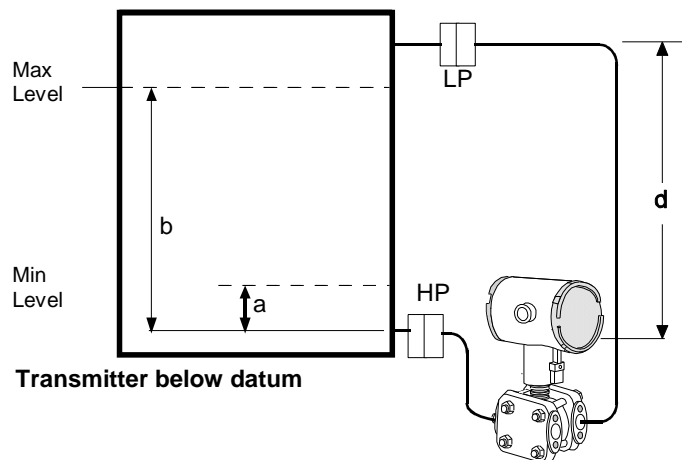

Transmitter below datum

Figure 19—Closed tank liquid level measurement distance

24253

Application Data (Cont'd)

Density or Interface*

Calculate the minimum and maximum pressure differentials to be measured (Figure 20).

$$P_{\min} = (SG_{\min} - SG_f) \times (d);$$

minimum density, 4mA output

$$P_{\max} = (SG_{\max} - SG_f) \times (d);$$

maximum density, 20mA output

Where:

d = distance between the taps

SG_{max} = maximum Specific Gravity

SG_{min} = minimum Specific Gravity

SG_f = Specific Gravity of capillary fill fluid (See Page 6 "Material Specifications" for values.)

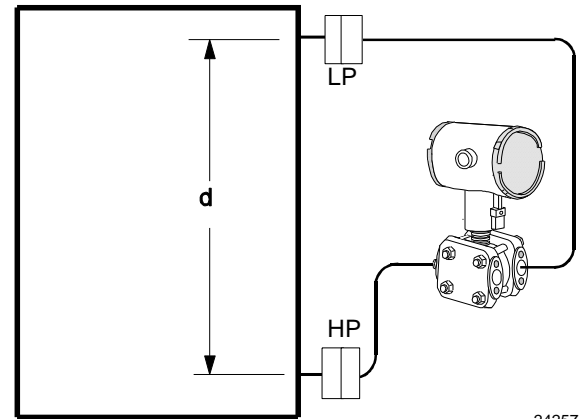

Figure 20—Density, direct acting transmitter configuration

Seal Configurations

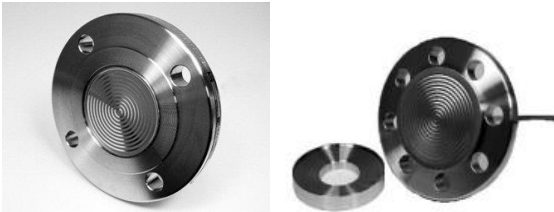

Figure 21—Flush Flange Seals and with left lower

Flush Flange Seals can be used with differential, gauge and absolute pressure transmitters and are available with 3" ANSI Class 150, ANSI Class 300 and DIN DN80-PN40 process connections. Flush flange seals can also be provided with Lower. Lower is essentially calibration rings, which allow flushing connections if needed



Figure 23—Pancake Seals

Pancake Seals can be used with differential, gauge and absolute pressure transmitters and are available with 3" ANSI Class 150, 300 and 600 process connections



Figure 22— Flange Seal with Extended Diaphragm

Flange Seal with Extended Diaphragm can be used with differential, gauge and absolute pressure transmitters and are available with 3" and 4" ANSI Class 150, ANSI Class 300, DIN DN80-PN40 and DIN DN100-PN40 process connections. 2", 4" and 6" extension lengths are available



Figure 24— Chemical Tee "Taylor" Wedge

Chemical Tee "Taylor" Wedge can be used with differential pressure transmitters and are available with Taylor Wedge 5" O.D. process connection

Seal Configurations (cont'd)



Figure 25— Seals with Threaded Process Connections

Seals with Threaded Process Connections can be used with differential, gauge and absolute pressure transmitters and are available with ½", ¾" and 1" NPT Female process connections



Figure 29— Stainless Steel Armor and PVC Coated Stainless Steel Armor Capillaries

Stainless Steel Armor and PVC Coated Stainless Steel Armor Capillaries are available with Honeywell Remote Seal Solutions



Figure 26— Sanitary Seals

Sanitary Seals can be used with differential, gauge and absolute pressure transmitters and are available with 3" and 4" Tri-Clover-Tri-Clamp process connections



Figure 30— 2" Stainless Steel Nipples

2" Stainless Steel Nipples are available for Close-Coupled remote seal solutions



Figure 27— Saddle Seals

Saddle Seals can be used with differential, gauge and absolute pressure transmitters and are available with 3" and 4" (6 bolt or 8 bolt designs) process connections



Figure 31— Welded Meter Body for All-Welded Remote Seal Solution

Welded Meter Body for All-Welded Remote Seal Solution. The welded ST 800 meter body is an important part of an All-Welded Remote Seal Solution, which is commonly used in Vacuum applications



Figure 28— Calibration Rings

Calibration Rings are available with Flush Flange Seals and Pancake Seals. Flushing ports (1/4" or 1/2") are available with calibration rings

Model Selection Guide

Model Selection Guides are subject to change and are inserted into the specifications as guidance only.

Model STR800 (DP, GP & AP) Remote Seals

Model Selection Guide
34-ST-16-88, Issue 34



Instructions

- Select the desired Key Number. The arrow to the right marks the selection available.
- Make selections from each Table (I, II and IX) using the column below the proper arrow.
- A (●) denotes unrestricted availability. A letter denotes restricted availability.
- Restrictions follow Table IX.

Key Number
STR ___ - [] - [] - [] - [] - [] - [] - [] - [] - [] + [] [] [] []

KEY NUMBER	URL	LRL	Max Span	Min Span	Units	Selection	Availability
Measurement Range Std Accuracy	400 (1000)	-400 (-1000)	400 (1000)	4 (10)	" H ₂ O (mbar)	STR82D	↓
	100 (7)	-100 (-7)	100 (7)	1 (0.07)	psi (bar)	STR83D	↓
	500 (35)	5.7 (0.39)	500 (35)	5 (0.35)	psia (bar A)	STR84A	↓
	500 (35)	-14.7 (-1.0)	500 (35)	5 (0.35)	psi (bar)	STR84G	↓
	3000 (210)	14.7 (-1.0)	3000 (210)	30 (2.1)	psi (bar)	STR87G	↓

Note: Remote seal pressure rating is body rating or seal rating, whichever is less.

TABLE I	Description		Selection	Availability		
Meter Body & Capillaries	a. Number of Seals	1 Remote Seal (High Side)	1 _____	●	●	
		2 Remote Seals	2 _____	●	●	
		1 Remote Seal (Low Side)	3 _____	●	●	
	b. Primary Fill Fluid (Meter body)	Silicone Oil 200	_1 _____	●	●	
		Fluorinated Oil CTFE	_2 _____	2	2	
		Silicone Oil 704	_3 _____	●	●	
		NEOBEE® M-20 ¹¹	_4 _____	●	●	
	c. Construction	Non-Wetted Adapter Head Materials				
		In-Line Gauge/ Absolute	316 SS Bonnet	_A _____		●
	316 SS Bonnet for Close-Couple		_B _____		3	
	Dual Head DP	316 SS (bolt-on heads)	_C _____	●		
		316 SS for Close-Couple	_D _____	3		
		316 SS with all-welded meter body	_E _____	4		
		None	_0 _____	22	●	
	d. Bolts and Nuts for Transmitter Heads	Carbon Steel Bolts and Nuts	_C _____	●		
316 SS Bolts and Nuts		_S _____	●			
A286 SS (NACE) Bolts and 304 SS (NACE) Nuts		_N _____	●			
B7M (NACE) Bolts and 7M (NACE) Nuts		_B _____	●			
e. Secondary Fill Fluid (capillary & seal)**		No Fill Fluid	_0 _____	5	5	
	Silicone Oil 200	_1 _____	●	●		
	Fluorinated Oil CTFE	_2 _____	●	●		
	Silicone Oil 704	_3 _____	●	●		
	Neobee® M20 ¹¹	_4 _____	●	●		
	Syltherm® 800 ¹²	_5 _____	●	●		
f. Connection of Remote Seal to Meter Body**	No Capillary, No Nipple (Specify for VAM Unit Only)		_0 _____	5	5	
	Capillary Length	5 feet 1.5 m	SS Armor	_A _____	●	●
		10 feet 3.0 m		_B _____	●	●
		15 feet 4.5 m		_C _____	●	●
		20 feet 6.1 m		_D _____	●	●
		25 feet 7.5 m		_E _____	●	●
		35 feet 10.7 m	_F _____	●	●	
		5 feet 1.5 m	PVC Coated SS Armor	_G _____	●	●
		10 feet 3.0 m		_H _____	●	●
		15 feet 4.5 m		_J _____	●	●
		20 feet 6.1 m		_K _____	●	●
	25 feet 7.5 m	_L _____		●	●	
	35 feet 10.7 m	_M _____	●	●		
	2 inch long SS nipple close-coupled		_2 _____	6	6	
g. Seal Option**	None	_0 _____	●	●		
	Std Gold Plated Seal Diaph. = 50 µin	_1 _____	7	7		
	Teflon Coated Seal Diaphragm - only for anti-sticking	_4 _____	7	7		

** Refer to 34-ST-00-128 for additional options, consult factory

¹¹ Limited vacuum availability.

¹² Minimum static pressure requirement. No vacuum allowed. See Specifications 34-ST-03-88 Figure 15



In-Line Gauge



Dual Head DP



All welded

STR84G & 87G & 84A
STR82D & 83D

Note: When selecting required seal, you must specify only the 9 selections within the required seal type.





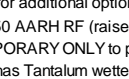

TABLE II		Description			Selection			
No Seal Attached to Core Transmitter (Specify for VAM Unit Only)					0 0 0 0 0 0 0 0	21	21	
Seal Type	Diaphragm Diameter	Flange Size	Flange Pressure Rating ¹		Selection			
 Flush Flanged Seal**	3.5"	3"	ANSI Class 150		AFA _____	•	•	
			ANSI Class 300		AFC _____	•	•	
		80mm	DIN DN80-PN40		AFM _____	•	•	
	 Wetted Material			Diaphragm	Upper Insert	Selection		
				316L SS	316L SS	___ AA ___	•	•
				Hastelloy [®] C-276	316L SS	___ AB ___	•	•
				Hastelloy [®] C-276	Hastelloy [®] C-276	___ AC ___	•	•
				Monel 400 [®]	Monel 400 [®]	___ AE ___	8	8
	Tantalum ⁵	316L SS	___ AF ___	8	8			
	 Non-Wetted Material (upper)			CS (Nickel Plated)		___ 1 ___	•	•
				316L SS		___ 2 ___	•	•
	 Seal-Capillary Connection			Center Seal		___ 1 ___	•	•
Side Seal				___ 2 ___	9	9		
 Calibration Rings			None		___ A ___	•	•	
			316L SS		___ B ___	10	10	
			Hastelloy [®] C-276		___ C ___	10	10	
			Monel 400 [®]		___ D ___	10	10	
 Flushing Connections and Plugs ⁴ (Metal plug material will be the same as Cal. ring material if metal plug is chosen)			None		___ 0 ___	•	•	
			One 1/4" with plastic plug		___ H ___	11	11	
			One 1/4" with metal plug		___ J ___	11	11	
			Two 1/4" with plastic plugs		___ M ___	11	11	
			Two 1/4" with metal plugs		___ N ___	11	11	
			One 1/2" with plastic plug		___ P ___	11	11	
			One 1/2" with metal plug		___ Q ___	11	11	
			Two 1/2" with plastic plugs		___ R ___	11	11	
Two 1/2" with metal plugs		___ S ___	11	11				

Table II continued next page

^{**} Refer to 34-ST-00-128 for additional options, consult factory

¹ Standard facing 125-250 AARH RF (raised face) serrated surface finish.

⁴ Plastic Plugs are TEMPORARY ONLY to protect threads and MUST be REMOVED before installation

⁵ Tantalum Upper insert has Tantalum wetted parts and 316 SS or CS non-wetted parts

Note: Remote seal system pressure rating is body rating or seal rating, whichever is less.

STR84G & 87G & 84A
STR82D & 83D

TABLE II		Descriptor				Selection				
Seal Type	Diaphragm Diameter	Flange Size	Flange Pressure Rating ¹	Const. - See Spec. Figure 34-ST-03-88	Construction - See Spec. Figure 34-ST-03-88					
Seals (continued)  Flush Flanged Seal with Lower**	2.4"	1"	ANSI 150 ANSI 300	22 22	BCA _____ BCC _____	12 12	• •	• •		
		1-1/2"	ANSI 150 ANSI 300	22 22	BGA _____ BGC _____	12 12	• •	• •		
		2"	ANSI 150 ANSI 300	22 22	BDA _____ BDC _____	12 12	• •	• •		
		3"	ANSI 150 ANSI 300	22 22	BFA _____ BFC _____	12 12	• •	• •		
		2.9"	1/2"	ANSI 150	23	CAA _____	•	•	•	
			1"	ANSI 150 ANSI 300	23 23	CCA _____ CCC _____	• •	• •	• •	
			1-1/2"	ANSI 150 ANSI 300	22 22	CGA _____ CGC _____	• •	• •	• •	
			2"	ANSI 150 ANSI 300	22 22	CDA _____ CDC _____	• •	• •	• •	
		4.1"	1/2"	ANSI 150	22	DAA _____	•	•	•	
			1"	ANSI 150 ANSI 300	23 23	DCA _____ DCC _____	• •	• •	• •	
			1-1/2"	ANSI 150 ANSI 300	23 23	DGA _____ DGC _____	• •	• •	• •	
			2"	ANSI 150 ANSI 300	23 22	DDA _____ DDC _____	• •	• •	• •	
			3"	ANSI 150 ANSI 300	22 22	DFA _____ DFC _____	• •	• •	• •	
		Wetted Material			Diaphragm	Lower	Selection			
					316L SS	316L SS	____ BA ____	•	•	•
					Hastelloy® C-276	316L SS	____ BB ____	•	•	•
			Hastelloy® C-276	Hastelloy® C-276	____ BC ____	•	•	•		
			Monel 400®	Monel 400®	____ BE ____	8	8	8		
			Tantalum	316L SS	____ BF ____	8	8	8		
			Tantalum	Hastelloy® C-276	____ BG ____	8	8	8		
			Tantalum	Tantalum Clad	____ BH ____	13	13	13		
	Non-Wetted Material (upper, upper insert)			Upper	Upper Insert	Selection				
				316L SS	316L SS	____ 4 ____	•	•	•	
			Carbon Steel	316L SS	____ 5 ____	•	•	•		
	Bolts ⁶		No Selection			____ 0 ____	•	•	•	
	Flushing Connections and Plugs ⁴		None			____ 0 ____	•	•	•	
	(Metal plug material will be the same as Lower material, if metal plug is chosen - (SS Plug for CS Lower and Tantalum Clad)		One 1/4" with plastic plug			____ H ____	•	•	•	
			One 1/4" with metal plug			____ J ____	•	•	•	
			Two 1/4" with plastic plugs			____ M ____	•	•	•	
			Two 1/4" with metal plugs			____ N ____	•	•	•	
			One 1/2" with plastic plug			____ P ____	•	•	•	
			One 1/2" with metal plug			____ Q ____	•	•	•	
Two 1/2" with plastic plugs			____ R ____	•	•	•				
Gasket		Klinger® C-4401 (non-asbestos)			____ K ____	•	•	•		
		Grafoil®			____ G ____	•	•	•		
		Teflon®			____ T ____	•	•	•		
		Gylon® 3510			____ L ____	15	15	15		

Table II continued next page

** Refer to 34-ST-00-128 for additional options. consult factory

¹ Standard facin 125-250 AARH RF (raised face) serrated surface finish.

⁶ Bolt material will be same as Upper Material. However, if Table I bolts/nuts material is NACE or B7M, seal bolt material will be 304 SS NACE.

⁴ Plastic Plugs are TEMPORARY ONLY to protect threads and MUST be REMOVED before installation

Note: Remote seal system pressure rating is body rating or seal rating, whichever is less.

STR84G & 87G & 84A
STR82D & 83D

TABLE II		Description			Selection		
Seal Type	Diaphragm Diameter	Flange Size	Flange Pressure Rating ¹		Selection		
 Flange Seal with Extended Diaphragm**	2.8"	3" (2.8" OD extension)	ANSI Class 150 ANSI Class 300 DIN DN80-PN40		EFA _____	•	•
					EFC _____	•	•
	3.5"	4" (3.70" OD extension)	ANSI Class 150 ANSI Class 300 DIN DN100-PN40		FGA _____	•	•
					FGC _____	•	•
					FGP _____	•	•
	Wetted Material		Diaphragm	Ext. Tube	Selection		
			316L SS	316L SS	___EA___	•	•
			Hastelloy® C-276	316L SS	___EB___	•	•
			Hastelloy® C-276	Hastelloy® C-276	___EC___	•	•
	Non-Wetted Material (flange)		CS (Nickel Plated)		___7___	•	•
		316L SS		___8___	•	•	
Bolts		No Selection		___0___	•	•	
Extension Length		2"		___2___	•	•	
		4"		___4___	•	•	
		6"		___6___	•	•	
No Selection	No Selection	No Selection		___0___	•	•	

Table II continued below

STR84G & 87G & 84A
STR82D & 83D

TABLE II		Description			Selection		
Seal Type	Diaphragm Diameter	Flange Size	Flange Pressure Rating Dependent on Customer Flange ¹		Selection		
 Pancake Seal	3.5"	3"	ANSI Class 150/300/600		GFA _____	•	•
	Wetted Material		Diaphragm	Body	Selection		
			316L SS	316L SS	___GA___	•	•
			Hastelloy® C-276	316L SS	___GB___	•	•
			Hastelloy® C-276	Hastelloy® C-276	___GC___	•	•
			Monel 400®	Monel 400®	___GE___	8	8
			Tantalum	Tantalum ⁷	___GG___	8	8
	Non-Wetted Material		No Selection		___0___	•	•
	Bolts		No Selection		___0___	•	•
Calibration Rings		None		___A___	•	•	
		316L SS		___B___	10	10	
		Hastelloy® C-276		___C___	10	10	
		Monel 400®		___D___	10	10	
Flushing Connections and Plugs ⁴ (Metal plug material will be the same as Cal. Ring material, if metal plug is chosen)		None		___0___	•	•	
		One 1/4" with plastic plug		___H___	11	11	
		One 1/4" with metal plug		___J___	11	11	
		Two 1/4" with plastic plugs		___M___	11	11	
		Two 1/4" with metal plugs		___N___	11	11	
		One 1/2" with plastic plug		___P___	11	11	
		One 1/2" with metal plug		___Q___	11	11	
		Two 1/2" with plastic plugs		___R___	11	11	
		Two 1/2" with metal plugs		___S___	11	11	

Table II continued next page

** Refer to 34-ST-00-128 for additional options, consult factory

¹ Standard facing 125-250 AARH RF (raised face) serrated surface finish.

⁴ Plastic Plugs are TEMPORARY ONLY to protect threads and MUST be REMOVED before installation

⁷ Tantalum Body has Tantalum wetted parts and 316 SS non-wetted parts

Note: Remote seal system pressure rating is body rating or seal rating, whichever is less.

STR84G & 87G & 84A
STR82D & 83D

TABLE II	Description						
Seal Type	Diaphragm Diameter	Flange Size	Flange Pressure Rating ¹		Selection		
 Chemical Tee "Taylor" Wedge	3.5"	Taylor Wedge 5" O.D.	750 psi		HMO _____	16	
	Wetted Material		Diaphragm	Body	Selection		
			316L SS	316L SS	--- HA ---	•	
			Hastelloy [®] C-276	316L SS	--- HB ---	•	
			Hastelloy [®] C-276	Hastelloy [®] C-276	--- HC ---	•	
	Non-Wetted Material		No Selection		----- 0 -----	•	
Bolts		No Selection		----- 0 -----	•		
Styles		No Selection		----- 0 -----	•		
No Selection		No Selection		----- 0 -----	•		

Table II continued below

STR84G & 87G & 84A
STR82D & 83D

TABLE II	Description							
Seal Type	Diaphragm Diameter	Threaded Process Connection Size (NPT Female)	Pressure Rating		Selection			
			CS Bolts	304 SS Bolts				
 Seal with Threaded Process Connection	2.4"	1/2 NPT	2,500 psi	1,250 psi	JJG _____	12	•	
		3/4 NPT			JKG _____	12	•	
		1 NPT			JLG _____	12	•	
	2.9"	1/2 NPT	2,500 psi	1,250 psi	KJG _____	•	•	
		3/4 NPT			KKG _____	•	•	
		1 NPT			KLG _____	•	•	
	4.1"	1/2 NPT	1,500 psi	750 psi	LJG _____	•	•	
		3/4 NPT			LKG _____	•	•	
		1 NPT			LLG _____	•	•	
	Wetted Material		Diaphragm	Lower	Selection			
			316L SS	Carbon Steel	--- JA ---	•	•	
			316L SS	316L SS	--- JB ---	•	•	
			Hastelloy [®] C-276	316L SS	--- JC ---	•	•	
			Hastelloy [®] C-276	Hastelloy [®] C-276	--- JD ---	•	•	
			Monel 400 [®]	Monel 400 [®]	--- JE ---	8	8	
		Tantalum	316L SS	--- JF ---	8	8		
		Tantalum	Hastelloy [®] C-276	--- JG ---	8	8		
Non-Wetted Material (upper)		CS (Nickel Plated) 316 Stainless Steel		----- A -----	•	•		
				----- C -----	17	17		
Bolts ⁸		Carbon Steel 304 SS		----- D -----	•	•		
Flushing Connections and Plugs ⁴		None		----- 0 -----	•	•		
(Metal plug material will be the same as Lower material, if metal plug is chosen - (SS Plug for CS Lower and Tantalum Clad)		One 1/4" with plastic plug		----- H -----	•	•		
		One 1/4" with metal plug		----- J -----	•	•		
		Two 1/4" with plastic plugs		----- M -----	•	•		
		Two 1/4" with metal plugs		----- N -----	•	•		
		One 1/2" with plastic plug		----- P -----	18	18		
		One 1/2" with metal plug		----- Q -----	18	18		
		Two 1/2" with plastic plugs		----- R -----	18	18		
		Two 1/2" with metal plugs		----- S -----	18	18		
Gasket		Klinger [®] C-4401 (non-asbestos) Grafoil [®] Teflon [®] Gylon [®] 3510		----- K -----	•	•		
				----- G -----	•	•		
				----- T -----	•	•		
				----- L -----	15	15		

Table II continued next page

¹ Standard facing 125-250 AARH RF (raised face) serrated surface finish.

⁴ Plastic Plugs are TEMPORARY ONLY to protect threads and MUST be REMOVED before installation

⁸ If Table I Bolts and Nuts material option is NACE, Bolts and Nuts will ship with Alloy Steel NACE and MAWP may change.

Note: Remote seal system pressure rating is body rating or seal rating, whichever is less.

STR84G & 87G & 84A
STR82D & 83D



TABLE II	Description							
Seal Type	Diaphragm Diameter	Flange Size	Pressure Rating		Selection			
Seals (continued)		1.9"	2"	Customer clamp rating or 600 psi, whichever is less		MD0 _____		19
		2.4"	2-1/2"			NE0 _____	20	19
		2.9"	3"			PF0 _____	19	19
		4.1"	4"			QG0 _____	19	19
	Wetted Material	Diaphragm		Body	Selection			
		316L SS		316L SS	___ N A ___	•	•	
	Non-Wetted Material	No Selection			___ 0 ___	•	•	
	Bolts	No Selection			___ 0 ___	•	•	
Styles	Tri-Clover Tri-Clamp®			___ 8 ___	•	•		
Gasket	No Selection			___ 0 ___	•	•		

Table II continued below

STR84G & 87G & 84A
STR82D & 83D

TABLE II	Description							
Seal Type	Diaphragm Diameter	Size and Bolt Pattern	Seal Pressure Rating		Selection			
			C.S. Bolts	316 SS Bolts				
Seals (continued)		2.4" 8-Bolt Design	for 3" Pipe ≥ 4" pipe	2,500 psi	1,250 psi	RFK _____	12	•
				RGK _____	12	•		
		2.4" 6-Bolt Design	for 3" Pipe ≥ 4" pipe	2,000 psi	1,000 psi	RPK _____	12	•
				RQK _____	12	•		
		Wetted Material	Diaphragm		Lower Housing	Selection		
			316L SS		Carbon Steel	___ RA ___	•	•
			316L SS		316L SS	___ RB ___	•	•
			Hastelloy® C-276		316L SS	___ RC ___	•	•
			Hastelloy® C-276		Hastelloy® C-276	___ RD ___	•	•
		Non-Wetted Material	Body		Bolts ^{10,11}	Selection		
Carbon Steel			Carbon Steel	___ B ___	8	8		
316L SS			316 SS	___ C ___	•	•		
Bolts	No Selection			___ 0 ___	•	•		
Styles	No Selection			___ 0 ___	•	•		
Gasket	Klinger® C-4401 (non-asbestos)			___ K ___	•	•		
	Grafoil®			___ G ___	•	•		
	Teflon®			___ T ___	•	•		
	Gylon® 3510			___ L ___	•	•		

⁹ All sanitary seals have dairy grade 3A approval.

¹⁰ Bolts are not included with "body only" selection.

¹¹ If Table I Bolts and Nuts material option is NACE, seal bolt material will be 304 SS NACE.
Note: Remote seal system pressure rating is body rating or seal rating, whichever is less.

STR84G & 87G & 84A
STR82D & 83D

TABLE III Agency Approvals (see data sheet for Approval Code Details)	
Approvals	No Approvals Required
	FM Explosion proof, Intrinsically Safe, Non-incendive, & Dustproof
	CSA Explosion proof, Intrinsically Safe, Non-incendive, & Dustproof
	ATEX Explosion proof, Intrinsically Safe & Non-incendive
	IECEX Explosion proof, Intrinsically Safe & Non-incendive
	SAEx Explosion proof, Intrinsically Safe & Non-incendive
	INMETRO Explosion proof, Intrinsically Safe & Non-incendive
	NEPSI Explosion proof, Intrinsically Safe & Non-incendive
	KOSHA Explosion proof, Intrinsically Safe & Non-incendive
	EAC Customs Union(Russia,Belarus,Kazakhstan) Ex Approval,Flameproof, Intrinsically Safe
	CCoE Explosion proof, Intrinsically Safe & Non-incendive
UATR Flameproof, Intrinsically Safe & Dustproof	

0	•	•
A	•	•
B	•	•
C	•	•
D	•	•
E	•	•
F	•	•
G	•	•
H	•	•
I	•	•
J	•	•
K	•	•

TABLE IV TRANSMITTER ELECTRONIC SELECTIONS						
a. Electronic Housing Material & Connection Type	Material		Connection	Lightning Protection		
	Polyester Powder Coated Aluminum		1/2 NPT	None		
	Polyester Powder Coated Aluminum		M20	None		
	Polyester Powder Coated Aluminum		1/2 NPT	Yes		
	Polyester Powder Coated Aluminum		M20	Yes		
	316 Stainless Steel (Grade CF8M)		1/2 NPT	None		
	316 Stainless Steel (Grade CF8M)		M20	None		
	316 Stainless Steel (Grade CF8M)		1/2 NPT	Yes		
316 Stainless Steel (Grade CF8M)		M20	Yes			
b. Output/ Protocol	Analog Output		Digital Protocol			
	4-20mA dc		HART Protocol			
	4-20mA dc none		DE Protocol Foundation Fieldbus			
c. Customer Interface Selections	Indicator		Buttons		Languages	
	None		None		None	
	None		Yes (Zero/Span Only)		None	
	Advanced		None		EN,GR,IT, FR,SP,RU, TU	
	Advanced		Yes		EN,GR,IT, FR,SP,RU, TU	
	Advanced		None		EN, CH, JP	
	Advanced		Yes		EN, CH, JP	
	Standard (w/internal Zero, Span & Conf Buttons)		None		EN, RU	
Standard (w/internal Zero, Span & Conf Buttons)		Yes		EN, RU		

A__	•	•
B__	•	•
C__	•	•
D__	•	•
E__	•	•
F__	•	•
G__	•	•
H__	•	•

H	•	•
D	•	•
F	•	•

__0	•	•
__A	f	f
__D	•	•
__E	•	•
__H	•	•
__J	•	•
__S	q	q
__T	q	q

TABLE V CONFIGURATION SELECTIONS			
a. Application Software	Diagnostics		
	Standard Diagnostics		
b. Output Limit, Failsafe & Write Protect Settings	Write Protect	Fail Mode	High & Low Output Limits ³
	Disabled	High> 21.0mAdc	Honeywell Std (3.8 - 20.8 mAdc)
	Disabled	Low< 3.6mAdc	Honeywell Std (3.8 - 20.8 mAdc)
	Enabled	High> 21.0mAdc	Honeywell Std (3.8 - 20.8 mAdc)
	Enabled	Low< 3.6mAdc	Honeywell Std (3.8 - 20.8 mAdc)
	Enabled	N/A	N/A Fieldbus or Profibus
c. General Configuration	Factory Standard		
	Custom Configuration (Unit Data Required from customer)		

1__	•	•
-----	---	---

1	f	f
2	f	f
3	f	f
4	f	f
5	g	g
6	g	g

__S	•	•
__C	•	•

TABLE VI CALIBRATION & ACCURACY SELECTIONS			
Accuracy and Calibration	Accuracy	Calibrated Range	Calibration Qty
	NA	None	None
	Standard	Factory Std	Single Calibration
	Standard	Custom (Unit Data Required)	Single Calibration

0	21	21
A	23	23
B	23	23

³ NAMUR Output Limits 3.8 - 20.5mAdc can be configured by the customer or select custom configuration Table Vc

STR84G & 87G & 84A
 STR82D & 83D

TABLE VII	ACCESSORY SELECTIONS	
a. Mounting Bracket	Bracket Type	Material
	None	None
	Angle Bracket	Carbon Steel
	Angle Bracket	304 SS
	Angle Bracket	316 SS
	Marine Approved Bracket	Carbon Steel
	Marine Approved Bracket (In Line)	Carbon Steel
	Marine Approved Bracket	304 SS
	Marine Approved Bracket (In Line)	304 SS
	Flat Bracket	Carbon Steel
Flat Bracket	304 SS	
Flat Bracket	316 SS	
b. Customer Tag	Customer Tag Type	
	No customer tag	
	One Wired Stainless Steel Tag (Up to 4 lines 26 char/line) Two Wired Stainless Steel Tag (Up to 4 lines 26 char/line)	
c. Unassembled Conduit Plugs & Adapters	Unassembled Conduit Plugs & Adapters	
	No Conduit Plugs or Adapters Required	
	1/2 NPT Male to 3/4 NPT Female 316 SS Certified Conduit Adapter	
	1/2 NPT 316 SS Certified Conduit Plug	
	M20 316 SS Certified Conduit Plug	
	Minifast [®] 4 pin (1/2 NPT) Minifast [®] 4 pin (M20)	

0 ___	•	•
1 ___	•	•
2 ___	•	•
3 ___	•	•
8 ___	y	•
9 ___		•
4 ___	y	
A ___		•
5 ___	•	•
6 ___	•	•
7 ___	•	•

_ 0 _ _	•	•
_ 1 _ _	•	•
_ 2 _ _	•	•

_ _ A0	•	•
_ _ A2	n	n
_ _ A6	n	n
_ _ A7	m	m
_ _ A8	n	n
_ _ A9	m	m

TABLE VIII	OTHER Certifications & Options : (String in sequence comma delimited (XX, XX, XX,...))
Certifications & Warranty	None - No additional options
	NACE MR0175; MR0103; ISO15156 (FC33338) Process wetted parts only
	NACE MR0175; MR0103; ISO15156 (FC33339) wetted and non-wetted parts
	Marine (DNV,ABS,BV,KR,LR)
	EN10204 Type 3.1 Material Traceability (FC33341)
	Certificate of Conformance (F3391)
	Calibration Test Report & Certificate of Conformance (F3399)
	Certificate of Origin (F0195)
	FMEDA (SIL 2/3) Certification (FC33337)
	Over-Pressure Leak Test Certificate (1.5X MAWP) (F3392)
	Cert Clean for O ₂ or CL ₂ service per ASTM G93
	Extended Warranty Additional 1 year
Extended Warranty Additional 2 years	
Extended Warranty Additional 3 years	
Extended Warranty Additional 4 years	
Extended Warranty "LifeTime" Additional 15 years	

00	*	*	
FG	*	*	b
F7	c	c	
MT	d	d	
FX	•	•	
F3	•	•	b
F1	•	•	
F5	•	•	
FE	j	j	
TP	•	•	
OX	e	e	
01	•	•	
02	•	•	
03	•	•	b
04	•	•	
15	•	•	

TABLE IX	Manufacturing Specials
Factory	Factory Identification

0 0 0 0	•	•
---------	---	---

MODEL RESTRICTIONS

Restriction Letter	Available Only With		Not Available With	
	Table	Selection(s)	Table	Selection(s)
b	Select only one option from this group			
d	IVa	C, D,G,H __	VIIa	1,2,3,5,6,7 __
c	Id	__ 0, N, B __		
e	Ib	__ 2 __ 2 __		
f			IVb	__ F __
g			IVb	__ H, D __
j	IVb	__ H __	Vb	__ 1,2,6 __
m	IVa	B, D, F, H __		
n	IVa	A, C, E, G __		
q	IVb	__ H __		
y			Ic	__ E __
2	Ie	__ 0 __ __ 2 __ __ 4 __		
3	If	__ 2 __	Ia	2
4	I	2 __ 0 __		
5	II	00000000	VIII	FG, F7, FX, OX,TP,MT,F1
6	I	__ B,D __	Ia	2
7			II	__ AF __ __ BF __ __ BG __ __ BH __ __ GG __ __ JF __ __ JG __
8			VIII	FG, F7
9	II	__ AA2 __ __ AB2 __		
10			II	__ 0
11			II	__ A __
12	If	__ A, G, 2 __		
13	II	__ 0 __	II VIII	__ T __ FG, F7
15	II	__ BF __ __ BG __ __ BH __ __ JF __ __ JG __		
16	I	2		
17			II	__ JA __
18			II	JJG JKG JLG
19			If	__ 2 __
20	If	__ A,G __		
21	I	__ 000		
22	Ic	__ E __		
23			II	00000000

FM ApprovalsSM is a service mark of FM Global
 Hastelloy[®] is a registered trademark of Haynes International
 Monel 400[®] is a registered trademark of Special Metals Corporation.
 HART[®] is a registered trademark of HART Communication Foundation.
 FOUNDATION[™] Fieldbus is a registered trademark of Fieldbus Foundation.
 Teflon[®] is a registered trademark of DuPont.
 Neobee[®] is a registered trademark of Stepan Company.
 Sylthem[®] 800 is a Trademark of Dow Corning Corporation
 Klinger[®] C-4401 is a registered trademark of THERMOSEAL, INC
 GRAFOIL[®] is a registered trademarks of GrafTech International Holdings Inc
 Gylon[®] 3510 is registered trademark of Garlock Sealing Technologies
 Tri-Clover Tri-Clamp[®] is a registered trademark of Alfa-Laval
 DC[®] 200 and DC[®] 704 are registered trademarks of Dow Corning

Sales and Service

For application assistance, current specifications, ordering, pricing, and name of the nearest Authorized Distributor, contact one of the offices below.

ASIA PACIFIC

Honeywell Process Solutions,

Phone: + 800 12026455 or
+44 (0) 1202645583

(TAC) hfs-tac-support@honeywell.com

Australia

Honeywell Limited

Phone: +(61) 7-3846 1255

FAX: +(61) 7-3840 6481

Toll Free 1300-36-39-36

Toll Free Fax:

1300-36-04-70

China – PRC - Shanghai

Honeywell China Inc.

Phone: (86-21) 5257-4568

Fax: (86-21) 6237-2826

Singapore

Honeywell Pte Ltd.

Phone: +(65) 6580 3278

Fax: +(65) 6445-3033

South Korea

Honeywell Korea Co Ltd

Phone: +(822) 799 6114

Fax: +(822) 792 9015

EMEA

Honeywell Process Solutions,

Phone: + 800 12026455 or
+44 (0) 1202645583

Email: (Sales)

FP-Sales-Apps@Honeywell.com

or

(TAC)

hfs-tac-support@honeywell.com

Web

Knowledge Base search

engine <http://bit.ly/2N5Vldi>

AMERICAS

Honeywell Process Solutions,

Phone: (TAC) (800) 423-9883
or (215) 641-3610

(Sales) 1-800-343-0228

Email: (Sales)

FP-Sales-Apps@Honeywell.com

or

(TAC)

hfs-tac-support@honeywell.com

Web

Knowledge Base search

engine <http://bit.ly/2N5Vldi>

Specifications are subject to change without notice.

For more information

To learn more about SmartLine Pressure

Transmitters, visit

www.process.honeywell.com Or contact

your Honeywell Account Manager

Process Solutions

Honeywell

1250 W Sam Houston Pkwy S

Houston, TX 77042

Honeywell Control Systems Ltd

Honeywell House, Skimped Hill Lane

Bracknell, England, RG12 1EB

Shanghai City Centre, 100 Jungi Road

Shanghai, China 20061

Honeywell

www.process.honeywell.com

34-ST-03-88
October 2023

©2023 Honeywell International Inc.