

STD800 SmartLine Differential Pressure Specification 34-ST-03-82, December 2023



Introduction

Part of the SmartLine® family of products, the STD800 is a high performance differential pressure transmitter featuring piezoresistive sensor technology. By combining differential pressure sensing with on chip static pressure and temperature compensation the STD800 offers high accuracy and stability over a wide range of application pressures and temperatures. The SmartLine family is also fully tested and compliant with Experion® PKS providing the highest level of compatibility assurance and integration capabilities. SmartLine easily meets the most demanding application needs for pressure measurement applications.

Best in Class Features:

- Accuracies up to 0.035% of span standard & 0.025% of span optional.
- Stability up to 0.01% of URL per year for 15 years.
- Automatic static pressure & temperature compensation.
- Rangeability up to 400:1.
- Response times as fast as 90ms.
- Multiple local display capabilities.
- External zero, span, & configuration capability.
- Polarity insensitive electrical connections.
- Comprehensive on-board diagnostic capabilities.
- Integral Dual Seal design for highest safety based on ANSI/NFPA 70-202 and ANSI/ISA 12.27.0.
- World class overpressure protection.
- Full compliance to SIL 2/3 requirements.
- Modular design characteristics.
- Available with additional 15-year warranty.
- Supports NAMUR NE-107 Extended Diagnostics (FF).
- Plugged Impulse Line Detection Option.
- Dual/Triple Calibration Option (HART & Fieldbus only).



Figure 1 – STD800 Differential Pressure Transmitters feature field-proven piezoresistive sensor technology

Communications/Output Options:

- 4-20mA
- Honeywell Digitally Enhanced (DE)
- HART® (version 7.0)
- FOUNDATION™ Fieldbus

All transmitters are available with the above listed communications protocols.

Span & Range Limits:

Model	URL inH ₂ O (mbar)	LRL inH ₂ O (mbar)	Min Span inH ₂ O (mbar)
STD810	10 (25)	-10 (-25)	0.1 (0.25)
STD815	-100 (-250)	100 (250)	0.5 (1.25)
STD820	400 (1000)	-400 (-1000)	1.0 (2.5)
Model	psi (bar)	psi (bar)	psi (bar)
STD830	100 (7.0)	-100 (-7.0)	1 (0.07)
STD870	3000 (210)	-100 (-7.0)	30 (2.1)

Description

The SmartLine family of gauge pressure, differential pressure, and absolute pressure transmitters is designed around a high performance piezo-resistive sensor. This one sensor integrates multiple sensors linking process pressure measurement with on-board static pressure (DP Models) and temperature compensation measurements resulting in the best total performance available. This level of performance allows the ST 800 to replace virtually any competitive transmitter available today.

Unique Indication/Display Options

The ST 800 modular design accommodates a standard alphanumeric LCD display or a unique advanced graphics LCD display with many unparalleled features.

Standard LCD Display Features

- Modular (may be added or removed in the field).
- Supports HART protocol variant.
- 0, 90, 180, & 270 degree position adjustments.
- Four configurable screens.
- Standard and custom measurement units available.
- Display calculated flow (square root) value in addition to analog output signal.
- 2 Lines 6 digits PV (9.95H x 4.20W mm) 8 Characters.
- Write protect Indication.
- Built in Basic Device Configuration through Internal or External Buttons – Range/Engineering Unit/Loop Test /Loop Calibration/Zero /Span Setting.
- Multiple language capabilities (EN, RU).

Advanced Graphics LCD Display Features

- Modular (may be added or removed in the field).
- 0, 90, 180, & 270 degree position adjustments.
- Up to eight display screens with 3 formats are possible.
- Standard and custom measurement units available.
- Large PV with Bar Graph or PV with Trend Graph.
- Configurable screen rotation timing (1 to 30 sec).
- Display calculated flow (square root) value in addition to analog output signal.
- Unique “Health Watch” indication provides instant visibility of diagnostics.
- Multiple language capability (EN, DE, FR, IT, ES, RU, TR, CN & JP).

Diagnostics

SmartLine transmitters all offer digitally accessible diagnostics which aid in providing advanced warning of possible failure events minimizing unplanned shutdowns, providing lower overall operational costs.

Configuration Tools

Integral Three Button Configuration Option

Suitable for all electrical and environmental requirements, SmartLine offer the ability to configure the transmitter and display via three externally accessible buttons when either display option is selected. Zero/span capabilities are also optionally available via these buttons with or without selection of a display option.

Handheld Configuration

SmartLine transmitters feature two-way communication and configuration capability between the operator and the transmitter. All Honeywell transmitters are designed and tested for compliance with the offered communication protocols and are designed to operate with any standards' compliant handheld configuration device such as Honeywell Versatilis Configurator.

Personal Computer Configuration

On a personal computer or laptop, Honeywell Field Device Manager (FDM) Software and FDM Express can be used for managing HART & Fieldbus device configurations.

System Integration

- SmartLine communications protocols all meet the most current published standards for HART/DE/Fieldbus.
- Integration with Honeywell's Experion PKS offers the following unique advantages.
 - Transmitter messaging.
 - Maintenance mode indication.
 - Tamper reporting.
 - FDM Plant Area Views with Health summaries.
 - All ST 800 units are Experion tested to provide the highest level of compatibility assurance.

Modular Design

To help contain maintenance & inventory costs, all ST 800 transmitters are modular in design supporting the user's ability to replace meter bodies, add indicators or change electronic modules without affecting overall performance or approval body certifications. Each meter body is uniquely characterized to provide in-tolerance performance over a wide range of application variations in temperature and pressure and due to the Honeywell advanced interface, electronic modules may be swapped with any electronics module without losing in-tolerance performance characteristics.

Modular Features:

- Meter body replacement
- Exchange/replace electronics/comms modules*
- Add or remove integral indicators*
- Add or remove lightning protection (terminal connection)*

* Field replaceable in all electrical environments (including IS) except flameproof without violating agency approvals.

With no performance effects, Honeywell's unique modularity results in **lower inventory needs and lower overall operating costs.**

Plugged Impulse Line Detection:

STD800 models are offered with a PILD option which provides indication of a plugged impulse line or process connection. When used in conjunction with an advanced display, a non-critical diagnostic indication appears on the integral display. For units without an integral display, an indication can be seen via the host or handheld device when HART Protocol is utilized.

Dual/Triple Calibration:

STD800 models are optionally offered with multiple calibrations. In lieu of a standard factory calibration, units can be supplied with 1, 2, or 3 customer specified calibrations. These calibrations are stored in the meter body and provide users with factory calibrated performance at up to three different calibrated ranges. This increases application flexibility without requiring any costly recalibration or additional inventory.

Performance Specifications

Reference Accuracy (conformance to +/-3 Sigma)

Table 1

Model	URL	LRL	Min Span	Maximum Turndown Ratio	Stability (% URL/Yr for 15 years)	Reference Accuracy ^{1,2} (% Span) Std/Opt
STD810	10 in H ₂ O (25mbar)	-10 in H ₂ O (-25mbar)	0.1 in H ₂ O (0.25mbar)	100:1	0.015	0.035
STD815	100 in H ₂ O (250mbar)	-100 in H ₂ O (-250mbar)	0.5 in H ₂ O (1.25mbar)	200:1	0.002	0.0375 / 0.025
STD820	400 in H ₂ O (1000mbar)	-400 in H ₂ O (-1000mbar)	1 in H ₂ O (2.5mbar)	400:1	0.010	0.0375 / 0.025
STD830	100 psi (7.0 bar)	-100 psi (-7.0 bar)	1 psi (0.07 bar)	100:1	0.020	0.0375 / 0.0325
STD870	3000 psi (210 bar)	-100 psi (-7.0 bar)	30 psi (2.1 bar)	100:1	0.010	0.0375 / 0.0350

Zero and span may be set anywhere within the listed (URL/LRL) range limits

Accuracy at Specified Span, Temperature and Static Pressure Effects: (conformance to +/-3)

Table 2

		Accuracy ^{1,2} (% of Span)				Combined Zero & Span Temperature Effect (% Span/28°C (50 °F))		Combined Zero & Span Static Line Pressure Effect (% Span/1000psi) ^{3,4}		
	Model	URL	Reference Turndown	A	B	C (see URL units)	D	E	F	G
Standard Accuracy	STD810	10 in H ₂ O (25mbar)	10:1	0.010	0.025	1 (2.5)	0.070	0.040	0.050	0.075
	STD815	100 in H ₂ O (250mbar)	20:1	0.005	0.0325	5 (12.5)	0.025	0.007	0.080	0.007
	STD820	400 in H ₂ O (1000mbar)	16:1	0.005	0.0325	25 (62.5)	0.025	0.007	0.080	0.007
	STD830	100 psi (7.0 bar)	6.7:1	0.005	0.0325	15 (1.05)	0.025	0.010	0.075	0.0075
	STD870	3000 psi (210 bar)	15:1	0.005	0.0325	200 (14)	0.025	0.006	0.075	0.0075
High Accuracy Option	STD815	100 in H ₂ O (250mbar)	20:1	0.005	0.0200	5 (12.5)	0.025	0.007	0.080	0.007
	STD820	400 in H ₂ O (1000mbar)	16:1	0.005	0.020	25 (62.5)	0.025	0.007	0.080	0.007
	STD830	100 psi (7 bar)	6.7:1	0.005	0.0275	15 (1.05)	0.025	0.010	0.075	0.0075
	STD870	3000 psi (210 bar)	15:1	0.005	0.030	200 (14)	0.025	0.006	0.075	0.0075
			Turn Down Effect			Temp Effect		Static Effect		
			$\pm [A + B]$ if Span $\geq C$ $\pm \left[A + B \left(\frac{C}{Span} \right) \right]$ if Span $< C$			$\pm \left[D + E \left(\frac{URL}{Span} \right) \right]$		$\pm \left[F + G \left(\frac{URL}{Span} \right) \right]$		

$$\text{Total Performance} = \pm \sqrt{(\text{Accuracy})^2 + (\text{Temp Effect})^2 + (\text{Static Line Pressure Effect})^2}$$

Total Performance Examples: (standard accuracy 5:1 Turndown, up to 50°F (28°C) shift & up to 1000 psi Static Pressure³)

STD810 @ 2 in H₂O	0.505% of span	STD830 @ 20 psi	0.140% of span
STD815	0.214% of span	STD870 @ 600 psi	0.131% of span
STD820 @ 80 in H₂O	0.135% of span		

Typical Calibration Frequency: Calibration verification is recommended every four (4) years

Notes:

1. Terminal based Accuracy – Includes combined effects of linearity, hysteresis and repeatability. Analog output adds 0.005% of span
2. For zero based spans and reference conditions of 25°C (77°F). 0 psig static pressure. 10 to 55% RH, and 316 Stainless Steel barrier diaphragm
3. STD810 includes only zero shift with static pressure. Results are % of span per 25 psig.
4. STD815 and STD825 Static Line Pressure effect units are % span per 500 psig.

Operating Conditions – All Models

Parameter	Reference Condition		Rated Condition		Operative Limits		Transportation and Storage	
	°C	°F	°C	°F	°C	°F	°C	°F
Ambient Temperature¹ STD800	25±1	77±2	-40 to 85	-40 to 185	-40 to 85	-40 to 185	-55 to 120	-67 to 248
Meter Body Temperature² STD810, 815, 820, 830, 870	25±1	77±2	-40 to 110 ¹	-40 to 230 ¹	-40 to 125	-40 to 257	-55 to 120	-67 to 248
Humidity %RH	10 to 55		0 to 100		0 to 100		0 to 100	
Vac. Region – Min. Pressure All Models Except STD810 mmHg absolute inH₂O absolute	Atmospheric Atmospheric		25 13		2 (short term) ³ 1 (short term) ³			
Supply Voltage Load Resistance	HART: 10.8 to 42.4 VDC at terminals (IS versions limited to 30 VDC), 0 to 1,440 ohms DE: 15 to 49.3VDC at terminals (IS versions limited to 30VDC), 0 to 1,200 ohms (as shown in Figure 2) FOUNDATION Fieldbus: 9.0 to 32.0 VDC at terminals, steady state current: 17.6mA, software download current: 27.4mA							
Maximum Allowable Working Pressure (MAWP)^{4,5} (ST 800 products are rated to Maximum Allowable Working Pressure. MAWP depends on Approval Agency and transmitter materials of construction.)	Standard: STD810 = 50 psi (3.45 bar) STD815 = 2,500 psi (172 bar) STD820, STD830 and STD870 = 4,500 psi (310 bar) Optional: STD820, STD830, STD870 = 6,000 psi (420 bar) Static Pressure Limit = Maximum Allowable Working Pressure (MAWP) = Overpressure Limit for ST 800 Differential Pressure Transmitters							

¹ LCD Display operating temperature -20°C to +70°C. Storage temperature -30°C to 80°C.

² Silicone 704 minimum temperature rating is 0°C (32°F). CTFE minimum temperature rating is -40°C (-40°F). NEOBEE M-20 minimum temperature rating is -15°C (5°F). NEOBEE[®] is a registered trademark of Stepan Company.

³ Short term equals 2 hours at 70°C (158°F).

⁴ MAWP applies for temperatures -40 to 125°C. Static Pressure Limit is de-rated to 3,000 psi for -26°C to -40°C. for all models except STD810, and STD815. Use of graphite. o-rings de-rates transmitter to 3,625 psi. Use of 1/2." process adaptors with graphite o-rings de-rates transmitter to 3,000 psi.

⁵ Consult factory for MAWP of ST 800 transmitters with CRN approval.

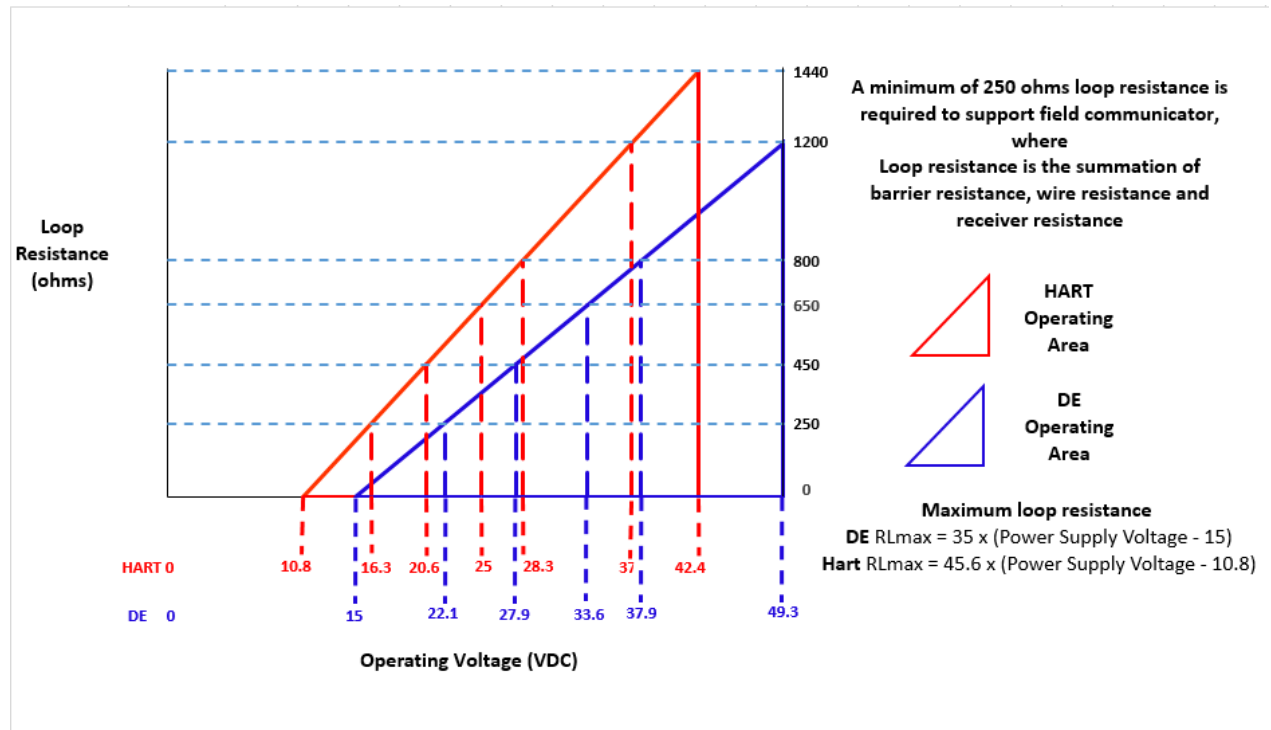

Figure 2 - Supply voltage and loop resistance chart & calculations

Performance Under Rated Conditions – All Models

Parameter	Description									
Analog Output Digital Communications:	Two-wire, 4 to 20 mA (HART & DE Transmitters only) Honeywell DE, HART protocol or FOUNDATION Fieldbus ITK 6.0.1 compliant All transmitters, irrespective of protocol have polarity insensitive connection									
HART & DE Output Failure Modes (NAMUR for DE Units requires selecting display and configuration buttons or factory configuration)	<table border="0"> <thead> <tr> <th></th> <th>Honeywell Standard</th> <th>NAMUR NE 43 Compliance</th> </tr> </thead> <tbody> <tr> <td>Normal Limits:</td> <td>3.8 – 20.8 mA</td> <td>3.8 – 20.5 mA</td> </tr> <tr> <td>Failure Mode:</td> <td>≤ 3.6 mA and ≥ 21.0 mA</td> <td>≤ 3.6 mA and ≥ 21.0 mA</td> </tr> </tbody> </table>		Honeywell Standard	NAMUR NE 43 Compliance	Normal Limits:	3.8 – 20.8 mA	3.8 – 20.5 mA	Failure Mode:	≤ 3.6 mA and ≥ 21.0 mA	≤ 3.6 mA and ≥ 21.0 mA
	Honeywell Standard	NAMUR NE 43 Compliance								
Normal Limits:	3.8 – 20.8 mA	3.8 – 20.5 mA								
Failure Mode:	≤ 3.6 mA and ≥ 21.0 mA	≤ 3.6 mA and ≥ 21.0 mA								
Supply Voltage Effect	0.005% span per volt									
Transmitter Turn on Time (includes power up & test algorithms)	HART or DE: 2.5 seconds Foundation Fieldbus: host dependent									
Response Time (delay + time constant)	<table border="0"> <thead> <tr> <th><u>DE/HART Analog Output</u></th> <th><u>FOUNDATION Fieldbus</u></th> </tr> </thead> <tbody> <tr> <td>90ms</td> <td>150ms (Host Dependent)</td> </tr> </tbody> </table>	<u>DE/HART Analog Output</u>	<u>FOUNDATION Fieldbus</u>	90ms	150ms (Host Dependent)					
<u>DE/HART Analog Output</u>	<u>FOUNDATION Fieldbus</u>									
90ms	150ms (Host Dependent)									
Damping Time Constant	HART: Adjustable from 0 to 32 seconds in 0.1 increments. Default: 0.50 seconds DE: Discrete values 0, .16, .32, .48, 1, 2, 4, 8, 16, 32 seconds. Default: 0.48 seconds									
Vibration Effect STD820, STD830, ST870	Less than +/- 0.1% of URL w/o damping Per IEC60770-1 field or pipeline, high vibration level (10-2000Hz: 0.21 displacement/3g max acceleration)									
Electromagnetic Compatibility	IEC 61326-3-1									
Lightning Protection Option	Leakage Current: 10uA max @ 42.4VDC 93C Impulse rating: 8/20us 5000A (>10 strikes) 10000A (1 strike min.) 10/1000us 200A (> 300 strikes)									

Materials Specifications (see model selection guide for availability/restrictions with various models)

Parameter	Description
Barrier Diaphragms Material	316L SS, Hastelloy® C-276 ² , Monel® 400 ³ , Tantalum, Gold-plated 316L SS, Gold-plated Hastelloy® C-276, Gold-plated Monel® 400
Process Head Material	316 SS ⁴ , Carbon Steel (Zinc-plated) ⁵ 316 SS ⁴ , Carbon Steel (Zinc-plated) ⁵ , Hastelloy C-276 ⁶ , Monel 400 ⁷
Vent/Drain Valves & Plugs ¹	316 SS ⁴ , Hastelloy C-276 ² , Monel 400 ⁷
Head Gaskets	Glass-filled PTFE standard. Viton® and graphite are optional.
Meter Body Bolting	Carbon Steel (Zinc plated) standard. Options include 316 SS, NACE A286 SS bolts, Monel K500, Super Duplex and B7M.
Optional Adapter Flange and Bolts	Adapter Flange materials include 316 SS, Hastelloy C-276 and Monel 400. Bolt material for flanges is dependent on process head bolts material chosen. Standard adaptor seal material is glass-filled PTFE. Viton and graphite are optional.
Mounting Bracket	Carbon Steel (Zinc-plated) or 304 Stainless Steel or 316 Stainless Steel
Fill Fluid	Silicone Oil 200, Silicone Oil 704, Inert Fluorinated Oil CTFE and NEOBEE® M-20 (Note that STD810 is only available with Silicone Oil 200 and NEOBEE® M-20)
Electronic Housing	Pure Polyester Powder Coated Low Copper (<0.4%)-Aluminum. Meets NEMA 4X, IP66, & P67. All stainless steel housing is optional.
Mounting	Can be mounted in virtually any position using the standard mounting bracket. Bracket is designed to mount on 2-inch (50 mm) vertical or horizontal pipe. See Figure 3.
Process Connections	1/4- NPT or 1/2- NPT with adapter (meets DIN requirements)
Wiring	Accepts up to 16 AWG (1.5 mm diameter).
Dimensions	See Figure 4.
Net Weight	8.3 pounds (3.8 Kg) with Aluminum Housing

¹ Vent/Drains are sealed with Teflon®² Hastelloy C-276 or UNS N10276³ Monel 400 or UNS N04400⁴ Supplied as 316 SS or as Grade CF8M, the casting equivalent of 316 SS.⁵ Carbon Steel heads are zinc-plated and not recommended for water service due to hydrogen migration. For that service, use 316 stainless steel wetted Process Heads.⁶ Hastelloy C-276 or UNS N10276. Supplied as indicated or as Grade CW12MW, the casting equivalent of Hastelloy C-276.⁷ Monel 400 or UNS N04400. Supplied as indicated or as Grade M30C, the casting equivalent of Monel 400.

Communications Protocols & Diagnostics

HART Protocol

Version: HART 7

Foundation Fieldbus (FF)

Available Function Blocks

Block Type	Qty	Execution Time
Resource	1	n/a
Transducer	1	n/a
Diagnostic	1	n/a
Analog Input	1*	30 ms
PID w/Autotune	1	45 ms
Integrator	1	30 ms
Signal Char (SC)	1	30 ms
LCD Display	1	n/a
Flow Block	1	30 ms
Input Selector	1	30 ms
Arithmetic	1	30 ms

* AI block may have two (2) additional instantiations. All available function blocks adhere to FOUNDATION Fieldbus standards. PID blocks support ideal & robust PID algorithms with full implementation of Auto-tuning.

Link Active Scheduler

Transmitters can perform as a backup Link Active Scheduler and take over when the host is disconnected. Acting as a LAS, the device ensures scheduled data transfers typically used for the regular, cyclic transfer of control loop data between devices on the Fieldbus.

Number of Devices/Segment

Entity IS model: 6 devices/segment

Schedule Entries

18 maximum schedule entries

Number of VCR's: 24 max

Compliance Testing: Tested according to ITK 6.0.1

Software Download

Utilizes Class-3 of the Common Software Download procedure as per FF-883 which allows the field devices of

any manufacturer to receive software upgrades from any host.

Honeywell Digitally Enhanced (DE)

DE is a Honeywell proprietary protocol which provides digital communications between Honeywell DE enabled field devices and hosts.

Standard Diagnostics

ST 800 top level diagnostics are reported as either critical or non-critical and are readable via the DD/DTM/FDI tools or integral display. All critical diagnostics will appear on the Advanced and Standard integral displays, and some non-critical diagnostics will also appear on the Advanced integral display. Some of the diagnostics are listed below.

Critical Diagnostics

- Electronics Module Fault
- Meter body Memory Corruption
- Config Data Corruption
- Electronics Module Diagnostics Failure
- Meter body Critical Failure
- Sensor Communication Timeout

Non-Critical Diagnostics

- Display Failure
- Electronics Module Comm Failure
- Meter body Excess Correct
- Sensor Over Temperature
- Fixed Current Mode
- PV Out of Range
- No DAC Compensation
- Tamper Attempt alarm

Refer to the product user manual for comprehensive list of diagnostics and details.

Other Certification Options

Materials

- NACE MRO175, MRO103, ISO15156

Hazardous Areal Certification

MSG CODE	AGENCY	TYPE OF PROTECTION	COMM. OPTION	ELECTRICAL PARAMETERS	AMBIENT TEMP (Ta)
A	FM Approvals™ USA	Explosionproof: Class I, Division 1, Groups A, B, C, D; Dust Ignition Proof: Class II, III, Division 1, Groups E, F, G; T6..T5 Class I, Zone 0/1, AEx db IIC T6..T5 Ga/Gb Class II, Zone 21, AEx tb IIIC T95° Db	All	Note 1	T5: -50 °C to 85°C T6: -50 °C to 65°C
		Intrinsically Safe: Class I, II, III, Division 1, Groups A, B, C, D, E, F, G: T4 Class I, Zone 0, AEx ia IIC T4 Ga FISCO Field Device (Only for FF Option) Ex ia IIC T4 Ga; Ex ic IIC T4 Gc	4-20 mA / DE/ HART	Note 2a	-50 °C to 70°C
		Nonincendive: Class I, Division 2, Groups A, B, C, D locations, T4 Class I, Zone 2, AEx nA IIC T4 Gc	Foundation Fieldbus	Note 2b	-50 °C to 70°C
		Nonincendive: Class I, Division 2, Groups A, B, C, D locations, T4 Class I, Zone 2, AEx nA IIC T4 Gc	4-20 mA / DE/ HART/ Foundation Fieldbus	Note 1	-50 °C to 85°C
		Enclosure: Type 4X/ IP66/ IP67	All	All	-
		STANDARDS: FM Class 3600:2011; FM Class 3610: 2010; FM Class 3611: 2004; FM Class 3615: 2006; FM Class 3616: 2011; FM Class 3810: 2005; ANSI/ISA 60079-0: 2013; ANSI/UL 60079-1: 2015; ANSI/UL 60079-11: 2014; ANSI/ISA 60079-15: 2012; ANSI/UL 60079-26: 2017; ANSI/UL 60079-31: 2015; ANSI/NEMA 250: 2003; ANSI/ IEC 60529: 2004			
B	Canadian Standards Association (CSA) USA and Canada	Explosion Proof: Class I, Division 1, Groups A, B, C, D; Class II, Division 1, Groups E, F, G; Class III, Division 1, T6..T5 Class I Zone 1 AEx db IIC T6..T5 Ga/Gb Ex db IIC T6..T5 Ga/Gb Zone 22 AEx tb IIIC T95° Db Ex tb IIIC T95° Db	All	Note 1	T5: -50°C TO 85°C T6: -50°C TO 65°C
		Intrinsically Safe: Class I, II, III, Division 1, Groups A, B, C, D; Class II, Division 1, Groups E, F, G; Class III, Division 1, T4 Class I Zone 0, AEx ia IIC T4 Ga Class I Zone 2, AEx ic IIC T4 Gc Ex ia IIC T4 Ga Ex ic IIC T4 Gc FISCO Field Device (Only for FF Option) Ex ia IIC T4 Ga; Ex ic IIC T4 Gc	4-20 mA / DE/ HART	Note 2	-50°C TO 70°C
		Nonincendive: Class I, Division 2, Groups A, B, C, D; Class II, Division 2, Groups F, G; Class III, Division 2, T4 Class I Zone 2 AEx nA IIC T4 Gc Ex nA IIC T4 Gc	Foundation Fieldbus	Note 2	-50°C TO 70°C
		Nonincendive: Class I, Division 2, Groups A, B, C, D; Class II, Division 2, Groups F, G; Class III, Division 2, T4 Class I Zone 2 AEx nA IIC T4 Gc Ex nA IIC T4 Gc	4-20 mA / DE/ HART/ Foundation Fieldbus	Note 1	-50°C to 85°C
		Enclosure: Type 4X/ IP66/ IP67	All	All	-
		STANDARDS: CSA C22.2 No. 0-10; CSA C22.2 No. 94-M91; CSA C22.2 No. 25-1966; CSA C22.2			

MSG CODE	AGENCY	TYPE OF PROTECTION	COMM. OPTION	ELECTRICAL PARAMETERS	AMBIENT TEMP (Ta)
		No. 30-M1986; CSA C22.2 No. 142-M1987; CSA C22.2 No. 157-92; CSA C22.2 No. 213-M1987; CSA-C22.2 No. 60529:05; CSA-C22.2 No. 60079-0:11; CSA-C22.2 No. 60079-1:11; CSA-C22.2 No. 60079-11:11; CSA-C22.2 No. 60079-15:12; CSA-C22.2 No. 60079-31:12; ISA 12.12.01-2010; ISA 60079-0: 2009; ISA 60079-11: 2011; ISA 60079-15: 2009; ISA 60079-26: 2008; ISA-60079-27:2007 (12.02.04)-2006 (R2011); UL 913 Ed. 6; UL 916:1998; ANSI/ISA-12.27.01-2011			
C	ATEX	Flameproof: SIRA 12ATEX2233X II 1/2 G Ex db IIC T6..T5 Ga/Gb II 2 D Ex tb IIIC T95°C...T120°C Db	All	Note 1	T5: -50°C TO 85°C T6: -50°C TO 65°C
		Intrinsically Safe: SIRA 12ATEX2233X II 1 G Ex ia IIC T4 Ga FISCO Field Device (Only for FF Option) II 1 G Ex ia IIC T4 Ga	4-20 mA / DE/ HART	Note 2	-50°C TO 70°C
			Foundation Fieldbus	Note 2	-50°C TO 70°C
		Zone 2, Increase Safety: SIRA 12ATEX4234X II 3 G Ex ec IIC T4 Gc	4-20 mA / DE/ HART/	Note 1	-50°C TO 85°C
		Zone 2, Intrinsically Safe: SIRA 12ATEX4234X II 3 G Ex ic IIC T4 Gc FISCO Field Device (Only for FF Option) II 3 G Ex ic IIC T4 Gc	4-20 mA / DE/ HART/ Foundation Fieldbus	Note 2	-50°C TO 85°C
		Enclosure: IP66/ IP67	All	All	-
		STANDARDS: EN 60079-0: 2012/A11: 2013; EN 60079-1: 2014; EN 60079-7: 2015; EN 60079-11: 2012; EN 60079-26: 2015; EN 60079-31: 2009			
D	IECEX World	Flameproof: IECEx SIR 12.0100X Ex db IIC T6..T5 Ga/Gb Ex tb IIIC T95°C...T120°C Db	All	Note 1	T5: -50°C TO 85°C T6: -50°C TO 65°C
		Intrinsically Safe: IECEx SIR 12.0100X Ex ia IIC T4 Ga FISCO Field Device (Only for FF Option) Ex ia IIC T4 Ga; Ex ic IIC T4 Gc	4-20 mA / DE/ HART	Note 2	-50°C TO 70°C
			Foundation Fieldbus	Note 2	-50°C TO 70°C
		Zone 2, Increase Safety: IECEx SIR 12.0100X Ex ec IIC T4 Gc	4-20 mA / DE/ HART/ Foundation Fieldbus	Note 1	-50°C TO 85°C
		Zone 2, Intrinsically Safe: IECEx SIR 12.0100X Ex ic IIC T4 Gc FISCO Field Device (Only for FF Option) Ex ic IIC T4 Gc	4-20 mA / DE/ HART/ Foundation Fieldbus	Note 2	-50°C TO 85°C
		Enclosure: IP66/ IP67	All	All	-
		STANDARDS: IEC 60079-0: 2011; IEC 60079-1: 2014; IEC 60079-7: 2017; IEC 60079-11: 2011; IEC 60079-26: 2014; IEC 60079-31: 2013			

E	SAEx South Africa	Flameproof : Ex d IIC T6...T5 Ga/Gb Ex tb IIIC T95°C...T120°C Db	All	Note 1	T5: -50°C TO 85°C T6: -50°C TO 65°C
		Intrinsically Safe: Ex ia IIC Ga T4 FISCO Field Device (Only for FF Option) Ex ia IIC T4 Ga; Ex ic IIC T4 Gc	4-20 mA / DE/ HART	Note 2	-50°C TO 70°C
			Foundation Fieldbus	Note 2	-50°C TO 70°C
		Zone 2, Increase Safety: II 3 G Ex ec IIC T4 Gc	4-20 mA / DE/ HART/ Foundation Fieldbus	Note 1	-50°C TO 85°C
		Zone 2, Intrinsically Safe: Ex ic IIC T4 Gc FISCO Field Device (Only for FF Option) Ex ic IIC T4 Gc	4-20 mA / DE/ HART/ Foundation Fieldbus	Note 2	-50°C TO 85°C
Enclosure: IP66/ IP67	All	All	-		
F	INMETRO Brazil	Flameproof: Ex db IIC T6..T5 Ga/Gb Ex tb IIIC T95°C...T120°C Db	All	Note 1	T5: -50°C TO 85°C T6: -50°C TO 65°C
		Intrinsically Safe: Ex ia IIC T4 Ga FISCO Field Device (Only for FF Option) Ex ia IIC T4 Ga; Ex ic IIC T4 Gc	4-20 mA / DE/ HART	Note 2a	-50°C TO 70°C
			Foundation Fieldbus	Note 2b	-50°C TO 70°C
		Zone 2, Increase Safety: II 3 G Ex ec IIC T4 Gc	4-20 mA / DE/ HART/ Foundation Fieldbus	Note 1	-50°C TO 85°C
		Zone 2, Intrinsically Safe: Ex ic IIC T4 Gc FISCO Field Device (Only for FF Option) Ex ic IIC T4 Gc	4-20 mA / DE/ HART/ Foundation Fieldbus	Note 2	-50°C TO 85°C
		Enclosure : IP 66/67	All	All	-
G	NEPSI CHINA	Flameproof: Ex db IIC T6..T5 Ga/Gb Ex tb IIIC T 95°C Db	All	Note 1	T5: -50°C TO 85°C T6: -50°C TO 65°C
		Intrinsically Safe: Ex ia IIC T4 Ga FISCO Field Device (Only for FF Option) Ex ia IIC T4 Ga; Ex ic IIC T4 Gc	4-20 mA / DE/ HART	Note 2	-50°C TO 70°C
			Foundation Fieldbus	Note 2	-50°C TO 70°C
		Zone 2, Increase Safety: II 3 G Ex ec IIC T4 Gc	4-20 mA / DE/ HART/ Foundation Fieldbus	Note 1	-50°C TO 85°C
		Zone 2, Intrinsically Safe: Ex ic IIC T4 Gc FISCO Field Device (Only for FF Option) Ex ic IIC T4 Gc	4-20 mA / DE/ HART/ Foundation Fieldbus	Note 2	-50°C TO 85°C
		Enclosure : IP 66/67	All	All	-

H	KOSHA Korea	Flameproof : Ex d IIC T4, T5, T6 Ex tD A21 IP66/IP67 T95°C...T120 °C	All	Note 1	T4: -50°C TO 85°C T5: -50°C TO 85°C T6: -50°C TO 65°C
		Intrinsically Safe: Ex ia IIC T4	4-20 mA / DE/ HART	Note 2	Ta= -50 °C to 70°C
			Foundation Fieldbus	Note 2	Ta= -50 °C to 70°C
		Enclosure: IP66/ IP67	All	All	-
I	EAC Russia, Belarus and Kazakhstan	Flameproof: Ga/Gb Ex d IIC T6..T5 Ex tb IIIC Db T 85°C	All	Note 1	T5: -50°C TO 85°C T6: -50°C TO 65°C
		Intrinsically Safe: Ga Ex ia IIC T4 X FISCO Field Device (Only for FF Option) Ga Ex ia IIC T4 X	4-20 mA / DE/ HART	Note 2	-50°C TO 70°C
			Foundation Fieldbus	Note 2	-50°C TO 70°C
		Zone 2, Non Sparking: 2 Ex nA IIC T4 Gc X	4-20 mA / DE/ HART/ Foundation Fieldbus	Note 1	-50°C TO 85°C
		Zone 2, Intrinsically Safe: Ga Ex ic IIC T4 X FISCO Field Device (Only for FF Option) 2 Ex ic IIC T4 Gc X	4-20 mA / DE/ HART/ Foundation Fieldbus	Note 2	-50°C TO 85°C
		Enclosure : IP 66/67	All	All	
J	CCoE INDIA	Flameproof: Ex d IIC T6..T5 Ga/Gb	All	Note 1	T5: -50°C TO 85°C T6: -50°C TO 65°C
		Intrinsically Safe: Ex ia IIC T4 Ga FISCO Field Device (Only for FF Option) Ex ia IIC T4 Ga; Ex ic IIC T4 Gc	4-20 mA / DE/ HART	Note 2	-50°C TO 70°C
			Foundation Fieldbus	Note 2	-50°C TO 70°C
		Non Sparking Ex nA IIC T4 Gc	4-20 mA / DE/ HART/ Foundation Fieldbus	Note 1	-50°C TO 85°C
Enclosure: IP66/ IP67	All	All	-		
K	UATR UKRAINE	Flameproof: II 1/2 G Ex db IIC T6..T5 Ga/Gb II 2 D Ex tb IIIC T95°C...T120°C Db	All	Note 1	T5: -50°C TO 85°C T6: -50°C TO 65°C
		Intrinsically Safe: II 1 G Ex ia IIC T4 Ga FISCO Field Device (Only for FF Option) II 1 G Ex ia IIC T4 Ga	4-20 mA / DE/ HART	Note 2	-50°C TO 70°C
			Foundation Fieldbus	Note 2	-50°C TO 70°C
		Enclosure: IP66/ IP67	All	All	-

Notes:

1. Operating Parameters:

Voltage = 11 to 42 VDC
= 10 to 30 V (FF)

Current = 4-20 mA Normal
= 30 mA (FF)

2. Intrinsically Safe Entity Parameters

a. Analog/DE/HART Entity Values

Vmax = Ui = 30V Imax= li = 105mA Ci = 4.2nF Li = 984 uH Pi = 0.9W

Transmitter with Terminal Block revision E or Later

Vmax = Ui = 30V Imax= li= 225mA Ci = 4.2nF Li = 0 Pi = 0.9W

Note: Transmitter with Terminal Block revision E or later

The revision is on the label that is on the module. There will be two lines of text on the label:

- First is the Module Part #: 50049839-001 or 50049839-002
- Second line has the supplier information, along with the REVISION:

XXXXXX-EXXX, THE "X" is production related, THE POSITION of the "E" IS THE REVISION

b. Foundation Fieldbus Entity Values

Vmax = Ui = 30V Imax = li = 180mA Ci = 0nF Li = 984 uH Pi = 1W

Transmitter with Terminal Block revision F or Later

Vmax = Ui = 30V Imax = li = 225mA Ci = 0nF Li = 0 Pi = 1 W

FISCO Field Device

Vmax = Ui = 17.5V Imax= li = 380 mA Ci = 0nF Li = 0 Pi = 5.32 W

Note : Transmitter with Terminal Block revision F or later

The revision is on the label that is on the module. There will be two lines of text on the label:

- First is the Module Part #: 50049839-003 or 50049839-004
- Second line has the supplier information, along with the REVISION:

XXXXXX-EXXX, THE "X" is production related, THE POSITION of the "E" IS THE REVISION

Approval Certifications

Marine Certificates	This certificate defines the certifications covered for the ST 800 Pressure Transmitter family of products, including the SMV 800 Smart Multivariable Transmitter. It represents the compilation of the five certificates Honeywell currently has covering the certification of these products into marine applications. For ST 800 Smart Pressure Transmitter and SMV800 Smart Multivariable Transmitter
	American Bureau of Shipping (ABS) - 2009 Steel Vessel Rules 1-1-4/3.7, 4-6-2/5.15, 4-8-3/13 & 13.5, 4-8-4/27.5.1, 4-9-7/13. Certificate number: 04-HS417416-PDA
	Bureau Veritas (BV) - Product Code: 389:1H. Certificate number: 12660/B0 BV
	Det Norske Veritas (DNV) - Location Classes: Temperature D, Humidity B, Vibration A, EMC B, Enclosure C. For salt spray exposure; enclosure of 316 SST or 2-part epoxy protection with 316 SST bolts to be applied. Certificate number: A-11476
	Korean Register of Shipping (KR) - Certificate number: LOX17743-AE001
	Lloyd's Register (LR) - Certificate number: 02/60001(E1) & (E2)
SIL 2/3 Certification	IEC 61508 SIL 2 for non-redundant use and SIL 3 for redundant use according to EXIDA and TÜV Nord Sys Tec GmbH & Co. KG under the following standards: IEC61508-1: 2010; IEC 61508-2: 2010; IEC61508-3: 2010.

Mounting & Dimensional Drawings

Mounting Configurations

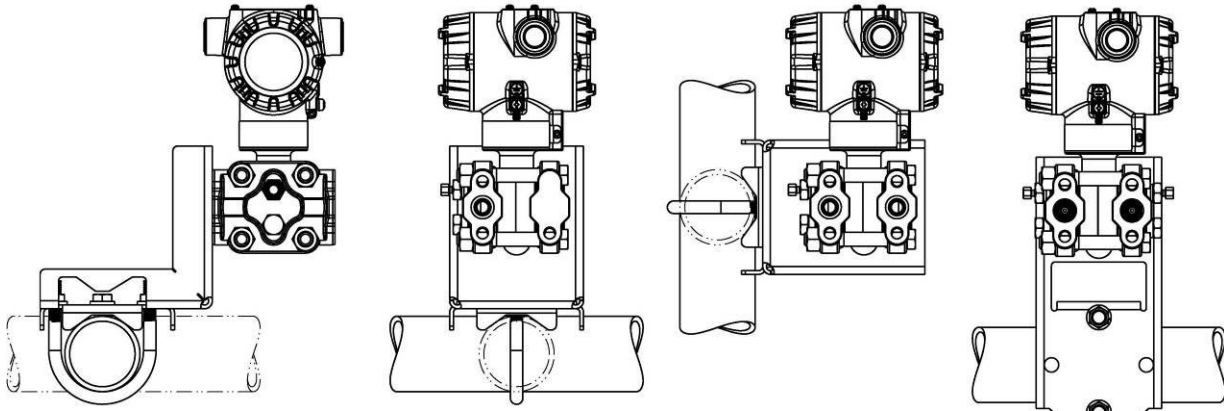

Figure 3 – Typical mounting configurations for STD810, STD815, STD820, STD830 and STD870 for reference

Reference Dimensions: $\frac{\text{millimeters}}{\text{inches}}$

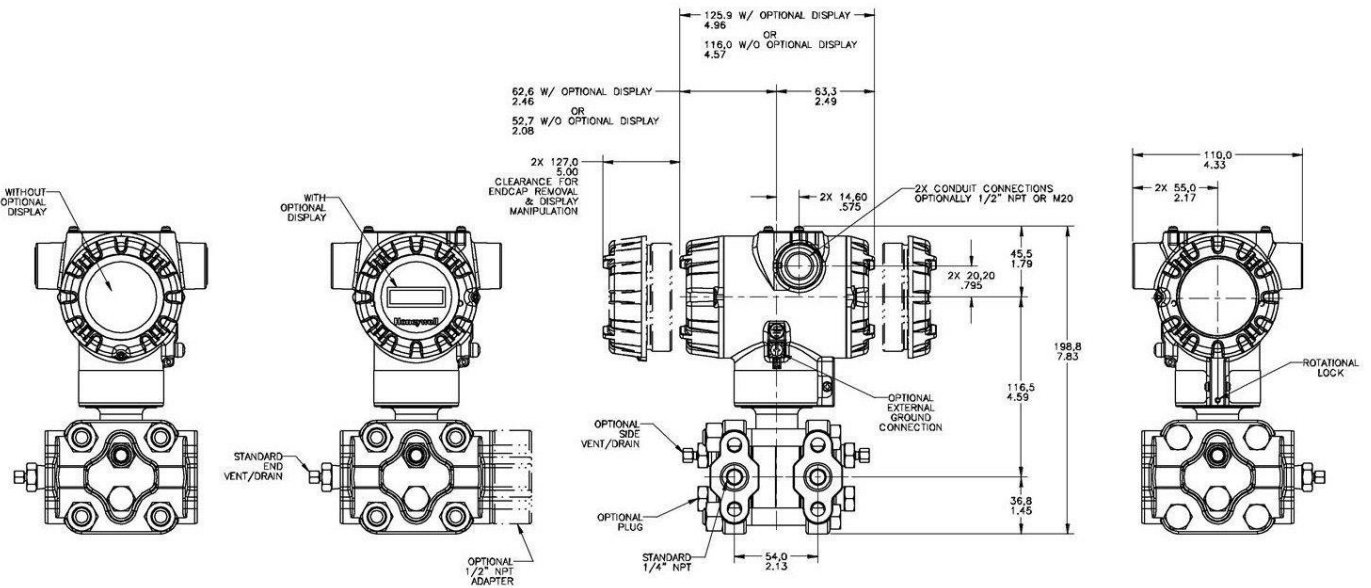

Figure 4 – Typical mounting dimensions of STD810, STD815, STD820, STD830 & STD870 for reference

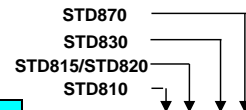
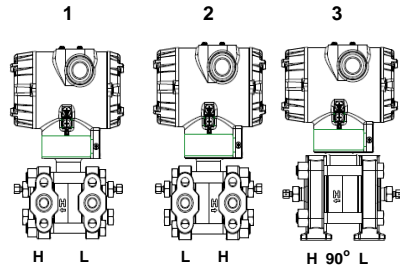

TABLE II		Meter Body & Connection Orientation	
Head/Connect Orientation	Standard	High Side Left, Low Side Right ² / Std Head Orientation	
	Reversed	Low Side Left, High Side Right ² / Std Head Orientation	
	90/Standard	High Side Left, Low Side Right ² / 90° Head Rotation	

1	*	*	*	*
2	*	*	*	*
3	h	h	h	h

TABLE III		Agency Approvals (see data sheet for Approval Code Details)	
Approvals	No Approvals Required		
	FM Explosion proof, Intrinsically Safe, Non-incendive, & Dustproof		
	CSA Explosion proof, Intrinsically Safe, Non-incendive, & Dustproof		
	ATEX Explosion proof, Intrinsically Safe & Non-incendive		
	IECEX Explosion proof, Intrinsically Safe & Non-incendive		
	SAEx Explosion proof, Intrinsically Safe & Non-incendive		
	INMETRO Explosion proof, Intrinsically Safe & Non-incendive		
	NEPSI Explosion proof, Intrinsically Safe & Non-incendive		
	KOSHA Explosion proof, Intrinsically Safe & Non-incendive		
	EAC Customs Union(Russia,Belarus,Kazakhstan)Ex Approval, Flame proof, Intrinsically Safe		
	CCoE Explosion proof, Intrinsically Safe & Non-incendive		
UATR Flameproof, Intrinsically Safe & Dustproof			

0	*	*	*	*
A	*	*	*	*
B	*	*	*	*
C	*	*	*	*
D	*	*	*	*
E	*	*	*	*
F	*	*	*	*
G	*	*	*	*
H	*	*	*	*
I	*	*	*	*
J	*	*	*	*
K	*	*	*	*

TABLE IV		TRANSMITTER ELECTRONICS SELECTIONS		
a. Electronic Housing Material & Connection Type	Material	Connection	Lightning Protection	
	Polyester Powder Coated Aluminum	1/2 NPT	None	
	Polyester Powder Coated Aluminum	M20	None	
	Polyester Powder Coated Aluminum	1/2 NPT	Yes	
	Polyester Powder Coated Aluminum	M20	Yes	
	316 Stainless Steel (Grade CF8M)	1/2 NPT	None	
	316 Stainless Steel (Grade CF8M)	M20	None	
	316 Stainless Steel (Grade CF8M)	1/2 NPT	Yes	
b. Output/ Protocol	Analog Output		Digital Protocol	
	4-20mA dc		HART Protocol	
	4-20mA dc none		DE Protocol Foundation Fieldbus	
c. Customer Interface Selections	Indicator	Ext Zero, Span & Config Buttons	Languages	
	None	None	None	
	None	Yes (Zero/Span Only)	None	
	Advanced	None	EN, GE, FR, IT, SP, RU, TU	
	Advanced	Yes	EN, GR, FR, IT, SP, RU, TU	
	Advanced	None	EN, CH, JP	
	Advanced	Yes	EN, CH, JP	
	Standard (w/internal Zero, Span & Conf Buttons)	None	EN, RU	
Standard (w/internal Zero, Span & Conf Buttons)	Yes	EN, RU		

A__	*	*	*	*
B__	*	*	*	*
C__	*	*	*	*
D__	*	*	*	*
E__	*	*	*	*
F__	*	*	*	*
G__	*	*	*	*
H__	*	*	*	*

H	*	*	*	*
D	u	u	u	u
F	*	*	*	*

_ _ 0	*	*	*	*
_ _ A	f	f	f	f
_ _ D	*	*	*	*
_ _ E	*	*	*	*
_ _ H	*	*	*	*
_ _ J	*	*	*	*
_ _ S	q	q	q	q
_ _ T	q	q	q	q

TABLE V		CONFIGURATION SELECTIONS		
a. Application Software	Diagnostics			
	Standard Diagnostics Advanced Diagnostics (Above with Plugged Impulse Detection PILD)			
b. Output Limit, Failsafe & Write Protect Settings	Write Protect	Fail Mode	High & Low Output Limits ³	
	Disabled	High> 21.0mAdc	Honeywell Std (3.8 - 20.8 mAdc)	
	Disabled	Low< 3.6mAdc	Honeywell Std (3.8 - 20.8 mAdc)	
	Enabled	High> 21.0mAdc	Honeywell Std (3.8 - 20.8 mAdc)	
	Enabled	Low< 3.6mAdc	Honeywell Std (3.8 - 20.8 mAdc)	
	Enabled	N/A	N/A Fieldbus or Profibus	
c. General Configuration	Factory Standard			
	Custom Configuration (Unit Data Required from customer)			

1__	*	*	*	*
2__	*	*	*	*

_ 1 _	f	f	f	f
_ 2 _	f	f	f	f
_ 3 _	f	f	f	f
_ 4 _	f	f	f	f
_ 5 _	g	g	g	g
_ 6 _	g	g	g	g

_ _ S	*	*	*	*
_ _ C	*	*	*	*

² Left side/Right side as viewed from the customer connection perspective

³ NAMUR Output Limits 3.8 - 20.5mAdc can be configured by the customer or select custom configuration Table Vc



TABLE VI CALIBRATION & ACCURACY SELECTIONS			
	Accuracy	Calibrated Range	Calibration Qty
Accuracy and Calibration	Standard	Factory Std	Single Calibration
	Standard	Custom (Unit Data Required)	Single Calibration
	Standard	Custom (Unit Data Required)	Dual Calibration
	Standard	Custom (Unit Data Required)	Triple Calibration
	High Accuracy	Factory Std	Single Calibration
	High Accuracy	Custom (Unit Data Required)	Single Calibration
	High Accuracy	Custom (Unit Data Required)	Dual Calibration
	High Accuracy	Custom (Unit Data Required)	Triple Calibration

A	*	*	*	*
B	*	*	*	*
C	*	*	*	*
D	*	*	*	*
E		s	s	s
F		s	s	s
G		s	s	s
H		s	s	s

TABLE VII ACCESSORY SELECTIONS		
	Bracket Type	Material
a. Mounting Bracket	None	None
	Angle Bracket	Carbon Steel
	Angle Bracket	304 SS
	Angle Bracket	316 SS
	Marine Approved Bracket	Carbon Steel
	Marine Approved Bracket	304 SS
	Flat Bracket	Carbon Steel
	Flat Bracket	304 SS
	Flat Bracket	316 SS
b. Customer Tag	Customer Tag Type	
	No customer tag	
	One Wired Stainless Steel Tag (Up to 4 lines 26 char/line)	
Two Wired Stainless Steel Tag (Up to 4 lines 26 char/line)		
c. Unassembled Conduit Plugs & Adapters	Unassembled Conduit Plugs & Adapters	
	No Conduit Plugs or Adapters Required	
	1/2 NPT Male to 3/4 NPT Female 316 SS Certified Conduit Adapter	
	1/2 NPT 316 SS Certified Conduit Plug	
	M20 316 SS Certified Conduit Plug	
	Minifast® 4 pin (1/2 NPT) (not suitable for X-Proof applications)	
	Minifast® 4 pin (M20) (not suitable for X-Proof applications)	

0 ___	*	*	*	*
1 ___	*	*	*	*
2 ___	*	*	*	*
3 ___	*	*	*	*
4 ___	*	*	*	*
5 ___	*	*	*	*
6 ___	*	*	*	*
7 ___	*	*	*	*

_ 0 _ _	*	*	*	*
_ 1 _ _	*	*	*	*
_ 2 _ _	*	*	*	*

_ _ A0	*	*	*	*
_ _ A2	n	n	n	n
_ _ A6	n	n	n	n
_ _ A7	m	m	m	m
_ _ A8	n	n	n	n
_ _ A9	m	m	m	m

TABLE VIII OTHER Certifications & Options: (String in sequence comma delimited (XX, XX, XX,...))	
Certifications & Warranty	None - No additional options
	Low Temperature Rating (-50 deg C min. ambient operative temperature limit)
	NACE MR0175; MR0103; ISO15156 (FC33338) Process wetted parts only
	NACE MR0175; MR0103; ISO15156 (FC33339) Process wetted and non-wetted parts
	Marine (DNV, ABS, BV, KR, LR)
	EN10204 Type 3.1 Material Traceability (FC33341)
	Certificate of Conformance (F3391)
	Calibration Test Report & Certificate of Conformance (F3399)
	Certificate of Origin (F0195)
	FMEDA (SIL 2/3) Certification (FC33337)
	Over-Pressure Leak Test Certificate (1.5X MAWP) (F3392)
	Cert Clean for O ₂ or CL ₂ service per ASTM G93
	PMI Certification ¹
	Extended Warranty Additional 1 year
	Extended Warranty Additional 2 years
Extended Warranty Additional 3 years	
Extended Warranty Additional 4 years	
Extended Warranty Additional 15 years	

00	*	*	*	*
LT	w	w	w	*
FG	*	*	*	*
F7	c	c	c	c
MT	d	d	d	d
FX	*	*	*	*
F3	*	*	*	*
F1	*	*	*	*
F5	*	*	*	*
FE	j	j	j	j
TP	*	*	*	*
OX	e	e	e	e
PM	*	*	*	*
01	*	*	*	*
02	*	*	*	*
03	*	*	*	*
04	*	*	*	*
15	*	*	*	*

TABLE IX Manufacturing Specials	
Factory	Factory Identification

0000	*	*	*	*
------	---	---	---	---

MODEL RESTRICTIONS

Restriction Letter	Available Only with		Not Available with	
	Table	Selection(s)	Table	Selection(s)
a			VIII	F7, FG
k			Ia	J,K,7,L,8
			Ic	H
			Id	B,D,M,N,S
			Ie	1, 2, 3, 5, 6
			III	B- No CRN number available
			If	C
c	1d	_ _ N,K,D,B _ _	Ia	D,H,K,L,8
d	IV a	C, D, G, H _ _	VIIa	1,2,3,5,6,7
e	Ib	2 _ _ _ _ _		
f			IVb	_ F _
g			IVb	_ H, D _
h			Ie	4, 5, 6
			VIIa	1,2,3,4,5,6,7,8
j	IVb	_ H _	Vb	_ 1,2,6 _
m	IV a	B, D, F, H _ _		
n	IV a	A, C, E, G _ _		
p			III	B- No CRN number available
q	IVb	_ H _		
t			Ia	J, K, 7, L, 8
s	Ia	A,E _ _ _ _ _		
u			Va	2
			VIIa	C,D,G,H
w	Ib	1 _ _ _ _ _	VIII	FE
y	Model Key	STD820		
z	Model Key	STD815		
b	Select only one option from this group			

¹The PM option is available on all Smartline Pressure Transmitter process wetted parts such as process heads, flanges, bushings and vent plugs except plated carbon steel process heads and flanges. PM option information is also available on diaphragms except Gold plated and STG and STA in-line construction pressure transmitters.

FIELD INSTALLABLE REPLACEMENT PARTS

Description	Kit Number	Price
Integrally Mounted Basic Indicator Kit (Compatible with all Electronic Modules)	50049911-501	Note P
Integrally Mounted Advanced Indicator Kit (compatible with all Electronic Modules)	50049846-501	Note P
Terminal Strip w/o Lightening Protection for HART or DE Modules	50075472-531	Note P
Terminal Strip w/Lightning Protection Kit for HART or DE Modules	50075472-532	Note P
Terminal Strip w/o Lightening Protection FFB/ <i>Profibus</i> Module	50075472-533	Note P
Terminal Strip w/Lightning Protection Kit for FFB/ <i>Profibus</i> Module	50075472-534	Note P
HART Electronics Module	50049849-501	Note P
HART Electronics Module w/connection for external configuration buttons	50049849-502	Note P
DE Electronics Module	50049849-503	Note P
DE Electronics Module w/connection for external configuration buttons	50049849-504	Note P
FFB Electronics Module Kit	50049849-507	Note P
FFB Electronics Module w/connection for external configuration buttons	50049849-508	Note P

Note P - For part number pricing please refer to WEB Channel.

PRODUCT MANUALS

Description	Part Number
ST 800 Smart Transmitter User Manual - English	34-ST-25-35
ST 800 Smart Transmitter HART/DE Communications Manual - English	34-ST-25-38
ST 800 Smart Transmitter Safety Manual - English	34-ST-25-37
ST 800 Smart Transmitter Foundation Fieldbus Manual - English	34-ST-25-39
ST 800 Smart Transmitter Function Block Manual - English	34-ST-25-42

All product documentation is available at www.process.honeywell.com.

Sales and Service

For application assistance, current specifications, ordering, pricing, and name of the nearest Authorized Distributor, contact one of the offices below.

ASIA PACIFIC

Honeywell Process Solutions,
Phone: + 800 12026455 or
+44 (0) 1202645583
(TAC) hfs-tac-support@honeywell.com

Australia

Honeywell Limited
Phone: +(61) 7-3846 1255
FAX: +(61) 7-3840 6481
Toll Free 1300-36-39-36
Toll Free Fax:
1300-36-04-70

China – PRC - Shanghai

Honeywell China Inc.
Phone: (86-21) 5257-4568
Fax: (86-21) 6237-2826

Singapore

Honeywell Pte Ltd.
Phone: +(65) 6580 3278
Fax: +(65) 6445-3033

South Korea

Honeywell Korea Co Ltd
Phone: +(822) 799 6114
Fax: +(822) 792 9015

EMEA

Honeywell Process Solutions,
Phone: + 800 12026455 or
+44 (0) 1202645583

Email: (Sales)

FP-Sales-Apps@Honeywell.com

or

(TAC)

hfs-tac-support@honeywell.com

Web

Knowledge Base search
engine <http://bit.ly/2N5Vldi>

AMERICAS

Honeywell Process Solutions,
Phone: (TAC) (800) 423-9883
or (215) 641-3610
(Sales) 1-800-343-0228

Email: (Sales)

FP-Sales-Apps@Honeywell.com

or

(TAC)

hfs-tac-support@honeywell.com

Web

Knowledge Base search
engine <http://bit.ly/2N5Vldi>

Specifications are subject to change without notice.

For more information

To learn more about SmartLine Pressure Transmitters,
visit www.process.honeywell.com
Or contact your Honeywell Account Manager

Process Solutions

Honeywell
1250 W Sam Houston Pkwy S
Houston, TX 77042

Honeywell Control Systems Ltd
Honeywell House, Skimped Hill Lane
Bracknell, England, RG12 1EB

Shanghai City Centre, 100 Jungi Road
Shanghai, China 20061

www.process.honeywell.com

Honeywell

34-ST-03-82
December 2023

©2023 Honeywell International Inc.