

KROHNE

▶ *achieve more*

For the highest level of quality

Product overview level measurement

Contents

3	Achieve more with KROHNE
5-7	Product selection
8-29	Continuous level measurement
30-37	Level switch
38-41	KROHNE services
42-43	Calibration/KROHNE proved

KROHNE trademarks
used in this brochure:

KROHNE
AST
CalSys
CARGOMASTER
Configure it
EcoMATE
KROHNE Care
OPTIBATCH
OPTIFLEX
OPTIFLUX
OPTIMASS
OPTISONIC
OPTISOUND
OPTISWIRL
OPTISWITCH
OPTIWAVE
WATERFLUX

Trademarks
of other owners:

Amphenol
FDT Group
FOUNDATION fieldbus
HART
HASTELLOY
Metaglas
PACTware
PROFIBUS
VARINLINE



Achieve more with KROHNE

KROHNE ranks among the world's leading companies involved in the development and production of innovative and reliable process measuring technology, providing solutions for all sectors around the globe. KROHNE was founded in 1921 in Duisburg. It has more than 2,700 employees and has a turnover of over 400 million euros. The company has 15 production facilities and owns 43 companies and joint ventures. In fact, KROHNE was the second company after VW to have a joint venture in Shanghai. Today, China is one of KROHNE's major markets. With an equity-to-assets ratio of approx. 42 %, the company is largely financially independent.

In the following, you will find the most important examples on the topic of level measurement:
In 1989, we put the world's first process radar device on the market – a milestone for the chemical and petrochemical industries, and for inland and overseas shipping. In 1995, KROHNE introduced the first TDR device, which was able to reliably determine both the level and the interface. This innovation benefits not only the food and beverage industry, but also the water and wastewater, the oil and gas and the paper and pulp industries.

In 2000, we developed the first FMCW device in a 2-wire design. This maintenance-free device replaced switches, displacement elements, ultrasonic devices and pressure transmitters and measured the distance, level and volume of liquids, pastes and sludges with a high degree of accuracy and reproducibility.

The next quantum leap in the field of non-contact level measurement came in 2004 with the OPTIWAVE/OPTIFLEX family. With these products, KROHNE not only revolutionized level measurement for complex applications involving foam or moving surfaces, but also introduced a new operating concept, which provides the user with options from start-up to the process control.

The innovative Drop antenna for OPTIWAVE was introduced in 2009. Its ellipsoidal shape prevents from product deposits in dusty or humid atmospheres. In 2012, we launched the modular housing concept with bayonet locking system for OPTIFLEX. The same concept is used for OPTIWAVE in 2013. Its unique PP/PTFE Wave Horn antennas make it the ideal device for measuring corrosive media.



The solution for any application

KROHNE has unique expertise in the field of level measurement technology. We show our capabilities not only in standard applications, but also in applications which are considered challenging and which require tailor-made solutions. For us, customer orientation begins in the research and development phase. Many of the products, which are now considered industrial standards, were developed by us in cooperation with our customers. Today, users benefit from KROHNE innovations: In 1990, KROHNE introduced the first process radar device and became the pioneer of using radar level measuring technology in process technology. In 1995, KROHNE also became the forerunner in the field of radar devices based on the TDR principle, using guided electromagnetic pulses. With the introduction of OPTIWAVE and OPTIFLEX in 2004, the market discovered the latest generation of radar and TDR technology. These devices are characterized by their high accuracy and reliability, even in difficult applications, and by a unique, innovative operating philosophy. A complete series of level switches for liquids and solids and mechanical level meters round out the KROHNE level portfolio. Even for challenging applications, e.g. at the highest temperatures and pressures, KROHNE offers corresponding customer-specific solutions.

Product selection list

The following table will help you in selecting the right measuring principle for your application

	BM 702 A	OPTIWAVE 5200 C/F	OPTIWAVE 6300 C	OPTIWAVE 7300 C	OPTIWAVE 8300 C Marine ¹	OPTISOUND 30x0
	Page 8/24	Page 8/24	Page 8/24	Page 8/25	Page 8/25	Page 9/26
Measuring principle	FMCW radar 10 GHz	FMCW radar 10 GHz	FMCW radar 24...26 GHz	FMCW radar 24...26 GHz	FMCW radar 24...26 GHz	Ultrasonic
Measuring range ≤ 30 m; ≤ 98.4 ft	x	x	x	x	x	x
Measuring range ≤ 40/45 m; ≤ 131.2/147.6 ft	-	-	x	x	x / -	x
Measuring range ≤ 80 m; ≤ 262.4 ft	-	-	x	x	-	o
Storage tanks	x	x	x	x	x	x
Still well/reference chambers	x	x	-	x	x	o
Process tanks	x	x	-	x	x	-
Complex process tanks (e.g. with agitators)	-	-	-	x	-	-
Bulk solids	-	-	x	-	-	x
Pressure ≤ 2 barg; ≤ 29 psig	x	x	x	x	x	x
Pressure ≤ 40 barg; ≤ 580 psig	x	x	x	x	x	-
Process connection tempe- rature ≤ +80°C; ≤ +176°F	x	x	x	x	x	x
Process connection tempe- rature ≤ +200°C; ≤ +392°F	x	x	x	x	x	-
Process connection tempe- rature ≤ +250°C; ≤ +482°F	x	x	-	-	-	-
Interface measurement	-	-	-	-	-	-
2-wire technology	x	x	x	x	x	x
4-wire technology	-	-	-	-	-	x
PROFIBUS® PA/FF (4-wire)	-	Q2 2013	-	-	-	-
Ex	x	x	x	x	x	x
SIL	-	x	-	-	-	-
Marine approvals	-	-	-	-	x	-

¹) marketed through our KROHNE Skarpenord sales office
x = suitable, o = suitable under certain conditions, - = not suitable

Product selection list

The following table will help you in selecting the right measuring principle for your application

	OPTIFLEX 1100 C	OPTIFLEX 2200 C/F	OPTIFLEX 1300 C	OPTIFLEX 4300 C Marine ¹
	Page 10/27	Page 10/27	Page 10/27	Page 10/27
Measuring principle	TDR Guided Radar	TDR Guided Radar	TDR Guided Radar	TDR Guided Radar
Measuring range ≤ 20 m; ≤ 65.6 ft	x	x	x	x
Measuring range ≤ 35 m; ≤ 114.8 ft		x	x	x
Measuring range ≤ 40 m; ≤ 131.2 ft		x		
Storage tanks	x	x	x	x
Still well/reference chambers	x	x	x	x
Process tanks	o	x	x	x
Complex process tanks (e.g. with agitators)		o	o	o
Bulk solids	x	x	x	x
Pressure ≤ 16 barg; ≤ 232 psig	x	x	x	x
Pressure ≤ 40 barg; ≤ 580 psig		x	x	x
Pressure ≤ 300 barg; ≤ 4351 psig			x	
Process connection temperature ≤ +100°C; ≤ +212°F	x	x	x	x
Process connection temperature ≤ +200°C; ≤ +392°F		x	x	x
Process connection temperature ≤ +300°C; ≤ +572°F		x	x	
Interface measurement			x	x
2-wire technology	x	x	x	x
PROFIBUS® PA/FF (4-wire)		Q2 2013		
Ex		x	x	x
SIL		x		
Marine approvals				x

x = suitable, o = suitable under certain conditions, - = not suitable
* longer devices on request

	BM 26 BASIC/ ADVANCED	BM 26 A	BM 26 W	BM 26 F	BW 25	BM 500
	Page 11/28	Page 11/28	Page 11/28	Page 11/29	Page 11/29	Page 11/29
Measuring principle	Magnetic bypass level indicator (MLI)	Magnetic bypass level indicator (MLI)	FMCW radar/magnetic bypass level indicator (MLI)	TDR guided radar/magnetic bypass level indicator (MLI)	Displacer	Potentiometric
Measuring range	5.3 m*; 17.4 ft*	5.5 m*; 18 ft*	5.4 m*; 17.7 ft*	5.5 m*; 18 ft*	5.5 m*; 18 ft*	3 m; 9.8 ft
Storage tanks	x	x	x	x	x	x
Still wells/reference chambers	x	x	x	x	x	x
Process tanks	x	x	x	x	x	-
Complex process tanks (e.g. with agitators)	x	x	x	x	o	-
Bulk solids	-	-	-	-	-	-
Pressure ≤40 barg; ≤580 psig	-	x	x	x	x	-
Flange temperature ≤ +200°C; ≤ +392°F	x	x	x	x	x	-
Interface measurement	-	x	-	x	x	-
2-wire technology	x	x	x	x	x	-
4-wire technology	-	-	-	-	x	x
PROFIBUS® PA/FF	x	x	x	x	x	-

x = suitable, o = suitable under certain conditions, - = not suitable
* longer devices on request



BM 702 A
2-wire FMCW radar
for simple applications

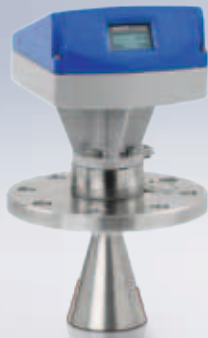

OPTIWAVE 5200 C
2-wire FMCW radar
for liquid applications



OPTIWAVE 5200 F
remote version 2-wire FMCW radar
for liquid applications



OPTIWAVE 6300 C/
Drop antenna
2-wire FMCW radar for
solid applications



OPTIWAVE 6300 C/7300 C/
Drop antenna
2-wire FMCW radar with
flange plate protection for
corrosive media



OPTIWAVE 7300 C/Horn antenna
2-wire FMCW radar for
liquid applications



OPTIWAVE 8300 C Marine
2-wire FMCW radar for marine
applications marketed through our
KROHNE Skarpenord sales office



OPTISOUND 3010
2-/4-wire ultrasonic level
meter for small tanks



OPTISOUND 3020
2-/4-wire ultrasonic level meter
for small and medium-sized tanks



OPTISOUND 3030
2-/4-wire ultrasonic level
meter for medium-sized tanks

Continuous level measurement



OPTIFLEX 1100 C
2-wire TDR guided radar
for storage or standard
process applications



OPTIFLEX 2200 C
2-wire TDR guided radar for
solid and liquid applications



OPTIFLEX 2200 F remote version
2-wire TDR guided radar for
solid and liquid applications



OPTIFLEX 1300 C
2-wire TDR guided radar for solid,
liquid and interface applications



OPTIFLEX 4300 C Marine
2-wire TDR guided radar for marine
applications marketed through our
KROHNE Skarpenord sales office



BM 26 BASIC/ADVANCED
Magnetic bypass level
indicator (MLI) for liquid
applications



BM 26 A
Magnetic bypass level
indicator (MLI) for liquid
and interface applications



BM 26 F
2-wire TDR guided radar
in a reference chamber
for liquid and interface
applications



BM 26 W
2-wire FMCW radar on
magnetic bypass level
indicator (MLI) for liquid
applications



BM 500
4-wire,
potentiometric



BW 25
The broadband displacer
system for high pressures
and temperatures

Continuous level measurement



Radar

Continuous level measurement via radar is based on the theory of the propagation of electromagnetic waves, put forth by the British physicist James C. Maxwell in 1865. Maxwell postulated that the field lines of a changing magnetic field are surrounded by annular electrical field lines, even in the absence of electrical conductors.

Inspired by this theory, German physicist Christian Hülsmeyer immediately applied for a patent for his telemobiloscope, the first radar device of this type in Düsseldorf in 1904. For this innovation, he is rightly known as the the inventor of the „original radar.“

In 1989, KROHNE introduced the first radar level meter for process tanks.

FMCW: Frequency Modulated Continuous Wave

The measuring principle

A radar signal is emitted via an antenna, reflected on the product surface and received after a time t . The radar principle used is FMCW (Frequency Modulated Continuous Wave). The FMCW radar emits a high frequency signal whose frequency increases linearly during the measurement phase (called the frequency sweep). The signal is emitted, reflected from the measuring surface and received with a time delay, t . Delay time, $t=2d/c$, where d is the distance to the product surface and c is the speed of light in the gas above the product. For further signal processing the difference Δf is calculated from the actual transmit frequency and the receive frequency. The difference is directly proportional to the distance. A large frequency difference corresponds to a large distance and vice versa. The frequency difference Δf is transformed via a Fourier transformation (FFT) into a frequency spectrum and then the distance is calculated from the spectrum. The level results from the difference between tank height and measuring distance.

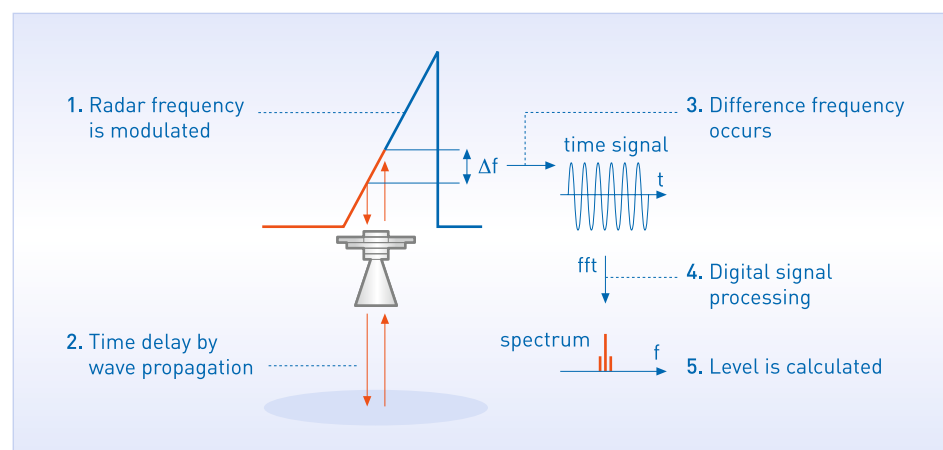

TDR: Time Domain Reflectometry

The measuring principle

The Guided Radar (TDR) level meter has been developed from a tried and tested technology called Time Domain Reflectometry (TDR).

The device transmits low-intensity electromagnetic pulses of approximately one nanosecond width along a rigid or flexible conductor. These pulses move at the speed of light. When the pulses reach the surface of the product to be measured, the pulses are reflected with an intensity that depends on the dielectric constant, ϵ_r , of the product (for example, water has a high dielectric constant and reflects the pulse back to the meter converter at 80 % of its original intensity).

The device measures the time from when the pulse is transmitted to when it is received: half of this time is equivalent to the distance from the reference point of the device (the flange facing) to the surface of the product. The time value is converted into an output current of 4 to 20 mA and/or a digital signal.

Dust, foam, vapor, agitated surfaces, boiling surfaces, changes in pressure, temperature and density do not have an effect on device performance.

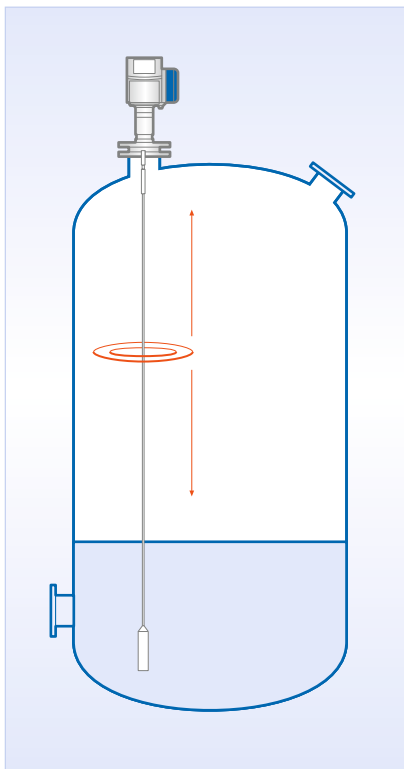

Highlights:

- Radar and TDR devices for liquid and solid applications
- Reliable measurement, even in tanks with moving surfaces, foam or inserts
- Suitable for very low or very high process temperatures/pressures (process connection temperature/pressure limits to be observed)
- Optional second current output for transferring additional measurement data
- Measuring distances up to 80 m; 262.47 ft
- Measurement of interfaces starting at 50 mm; 1.97"
- High standard accuracy beyond ± 2 mm; 0.08"
- Several TDR probes including twin-rod and twin-cable versions
- Several antenna options e.g. unique PP or PTFE Wave Horn antennas for corrosive media
- Optional antenna purging/heating or cooling
- Remote version up to 100 m; 328 ft
- Quick coupling system: converter can be rotated and removed under process conditions
- Metaglas® dual process sealing system for dangerous products
- Horizontal and vertical housing positions
- SIL2-compliant acc. to IEC 61508 for safety-related systems

User-friendly installation and set-up OPTIFLEX and OPTIWAVE family

With the TDR and FMCW radar level meters that leave our factory you not only get the experience and expertise of nearly two decades, but also an operating concept that sets a new standard for the industry.

This starts with the high-resolution, user-friendly display for simple and comfortable operation, followed by easy set-up with the help of our installation wizard. For additional ease of use, the display keypad is accessible without having to open the housing. Besides, the quick-coupling system permits removal of the converter under process conditions and also rotation through 360°.

With the innovative, modular housing of the OPTIFLEX 2200 C/F and OPTIWAVE 5200 C/F, the customer can specify the orientation and the position of the display. This makes it accessible, regardless of whether it is installed on a tank, in a recess or in buildings with small clearance to e.g. the roofs. The F-version features a remote installed signal converter with display and keypad. It allows installation and operation up to 100 m; 328 ft away from the antenna, e.g. in a control room or at the bottom of the tank. Both, OPTIFLEX 2200 C and OPTIWAVE 5200 C are designed and developed for use in safety-related systems according to IEC 61508 (SIL 2). Their converters are backwards compatible with flange systems of former TDR and FMCW radar meters from KROHNE. This will quickly bring your existing measuring equipment up to date so that it conforms to the highest standards and provide you with options such as SIL, ATEX, Fieldbus Foundation, PROFIBUS® PA and HART®.

The mechanical design of our OPTIFLEX/OPTIWAVE series features a selection of unique probes and antennas for standard and corrosive products making it ideal for all industries and a large variety of liquid and solid applications.

Highlights installation and set-up:

- Quick coupling system permits removal of the converter under process conditions
- Remote converter: up to 100 m; 328 ft away from the probe
- Easy installation using Quick Setup wizards with comprehensive help functions
- Uncomplicated navigation using a touchscreen (4-button operation)
- Display in nine languages, including Chinese, Japanese and Russian

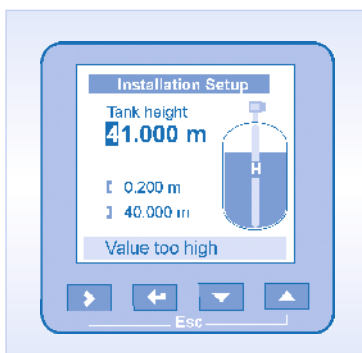
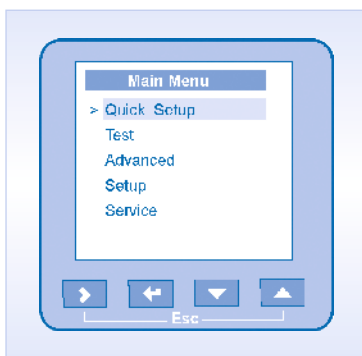

Empty spectrum

All interference reflections, which are caused by fixed or moving tank inserts and the bottom of the tank, can be detected and saved by recording an empty spectrum. The surface reflections are reliably detected, distinguished from interference reflections and analyzed by comparing the empty spectrum to the reflections in the filled state. For applications with tanks that cannot be emptied at the time of the start-up, the radar meters offer the capability of recording a partially empty spectrum.

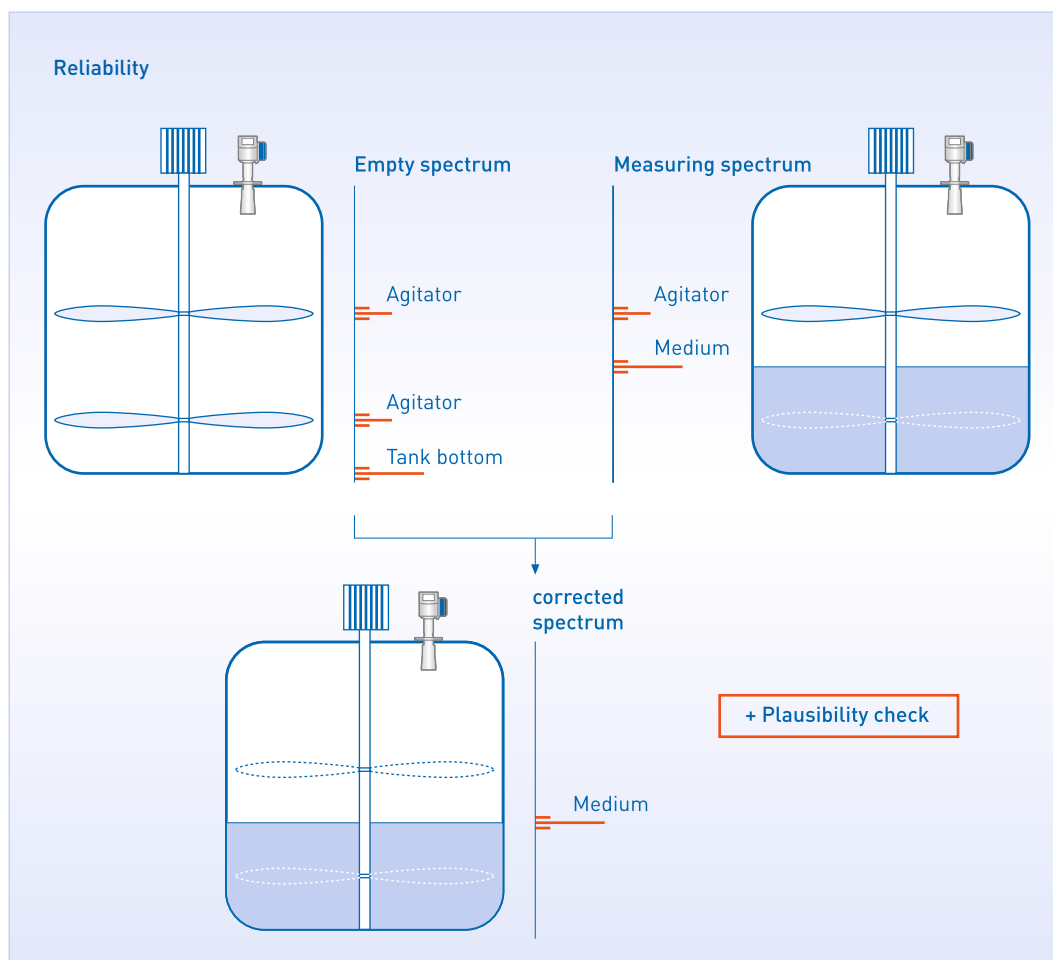

Ultrasonic

Highlights:

- Continuous level measurement of liquids and solids
- Suitable for sumps, water and wastewater basins
- Non-Contact flow measurement and detection in open channels
- Level detection of solids in silos and storage tanks
- Level measurement in stone crushers
- Profile measurement on conveyor belts

The measuring principle

Short ultrasonic pulses in the range of 18 to 70 kHz are sent from the signal transducer to the product to be measured, reflected from the surface of the fill goods and received by the signal transducer. The pulses propagate at the speed of sound, where the time between the sending and receiving of the signals depends on the level in the tank. The latest microprocessor technology and the tried and tested analysis software ensure that you will be able to reliably determine the level echo even when interference reflections are present and to calculate the exact distance to the surface of the fill goods. To compensate for the duration of the acoustic signal, an integrated sensor detects the temperature in the tank.

A level-proportional signal is formed from the distance by simply inputting the tank dimensions. It is not necessary to fill the tank for the adjustment.

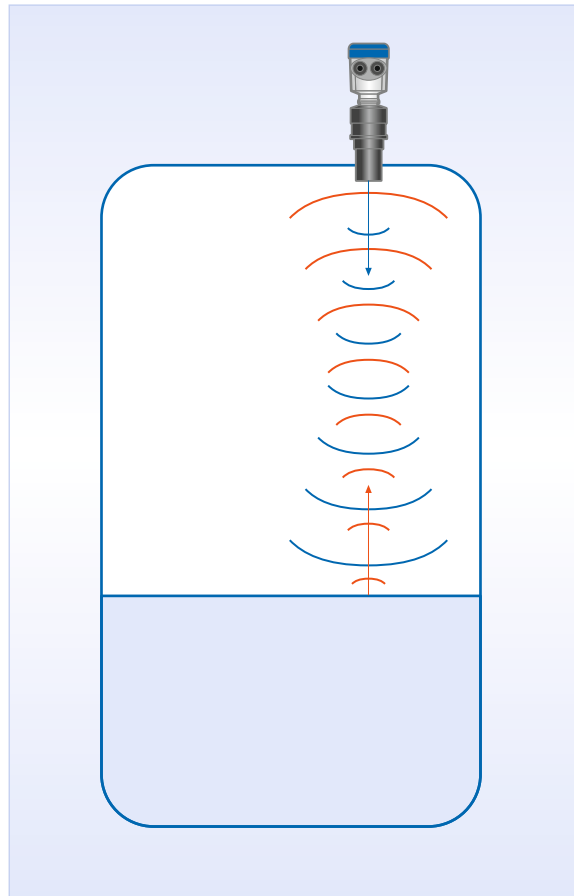



OPTISOUND – The innovative ultrasonic solution for liquids and solids

Ultrasonic level meters from KROHNE are used for continuous measurement of liquids and bulk goods in nearly all sectors of industry.

With the OPTISOUND, KROHNE introduced a family of products at Interkama 2005, which impressively demonstrates its superiority, particularly in open channels, in process tanks and in storage tanks, but also in basins, wastewater tanks and on conveyor belts. Continuous ultrasonic level measurement has proven itself in the field of „free level measurement.“

OPTISOUND is suitable for rainwater and wastewater, for low and high degrees of contamination, for silting or for liquids with a percentage of solids: in this case, the OPTISOUND can make full use of the advantages of contact-free measurement.

Bulk goods naturally pose different challenges to a meter than do liquids.

The surface of the product is not smooth, but generally forms a cone of bulk goods. Many products cause a heavy dust build-up. In addition, most solid silos are taller than the tanks for liquids. In this case too, OPTISOUND is the best choice.

By means of differently adjusted transmitting frequencies, the device can measure levels in a range from 0.25 to 15 m; 0.82 to 49.2 ft for liquids, from 0.25 to 7 m; 0.82 to 23 ft. Another advantage: Depending on the design, highly resistant materials for acoustic signal transducers and process connections guarantee their use, even with caustic media. Ingenious details such as an optionally available mounting bracket for easy alignment of the sensor round out the extremely positive overall impression of this series of devices.

Industries:

- Water and wastewater
- Chemical
- Metal
- Power generation
- Pulp and paper

Highlights:

- Proven technology with more than 40 years of experience in manufacturing
- Rugged stainless steel design – low or no maintenance
- Flaps housed in a hermetically sealed glass tube (IP68)
- Highly visible level indication works without power supply
- Large variety of accessories and options: special materials, valves, high and low temperature insulation, hazardous area approvals, limit switches, analogue transmitters, radar meters, interface measurement etc.
- Measuring ranges from 0.3 m; 1 ft up to 5.5 m; 18 ft (longer on request)
- Totally redundant measurement by technology and predictive maintenance monitoring possible when equipped with two independent transmitters

Industries:

- Water and wastewater
- Chemical
- Metal
- Power generation
- Pulp and paper

Float

The measuring principle

The magnetic bypass level indicator (MLI) operates on the principle of communicating vessels. The measuring chamber is connected adjacent to the tank so that the same conditions are obtained in the chamber as those in the tank. The float is equipped with a system of permanent magnets to transmit measured values to the local indicator. The magnet system of the float activates either the magnetic flaps according to the liquid level, or a movable follower magnet in the indicating section of the indicator depending on the method of indication chosen. The column of reversed yellow magnetic flaps, or the vertical position of the follower magnet, indicates the liquid level.

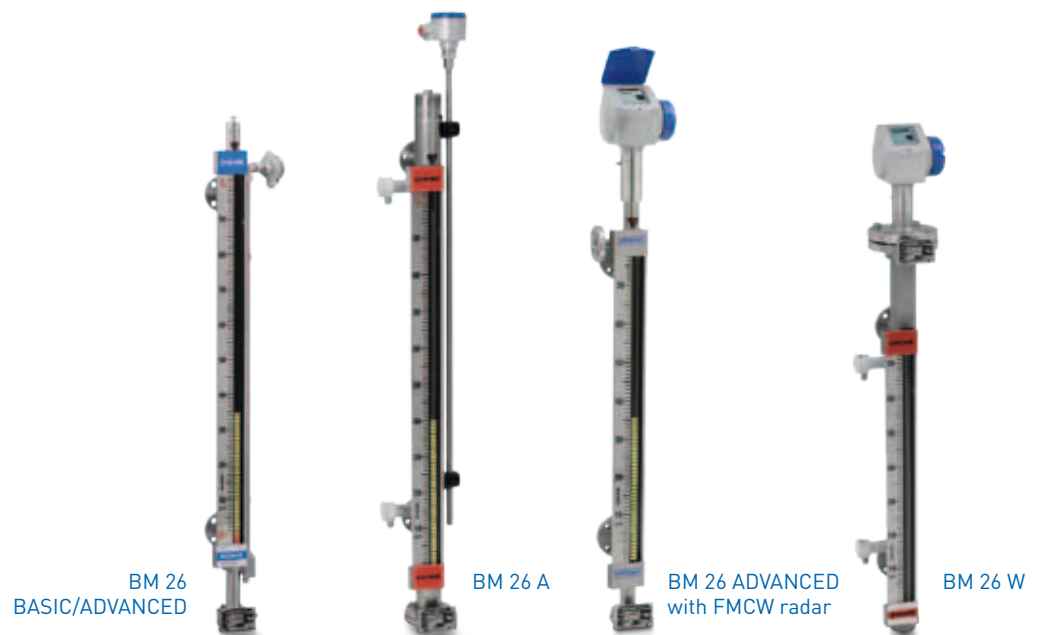
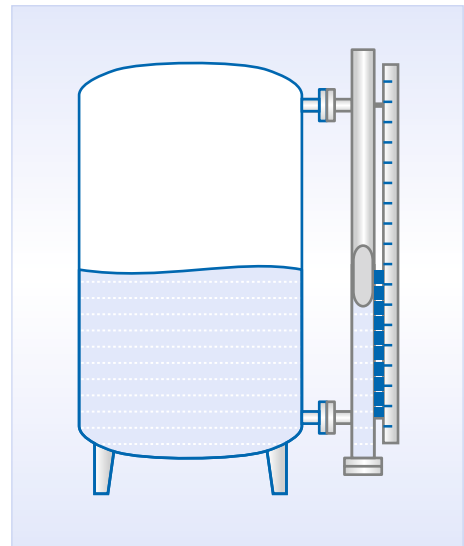

BM 26 BASIC/ADVANCED – Applications up to 40 barg; 580 psig

These two indicators use the same proven technology as other devices in the BM 26 range and offer the best price/performance ratio. Their optimal design keeps weight to a minimum. The BASIC version is ideal for measuring liquids in low-pressure storage and process tanks. The ADVANCED version, designed for chemical or petrochemical processes, indicates the level of hydrocarbons in refining applications etc.

BM 26 A – The universal float solution for level or separating layer

This indicator operates over a wide temperature range and at high pressures. It is also the perfect device for restricted spaces. The PTFE lined as well as the KP versions can be used with corrosive liquids.

BM 26 W / F – Measurement with double certainty

BM 26 A combined with an OPTIWAVE 7300 C FMCW radar level meter (BM 26 W) or an OPTIFLEX 1300 C TDR guided radar level meter (BM 26 F) permits totally redundant measurement where the measuring results of the radar meter can be checked against those from the Magnet Bypass Level Indicator (MLI). Both technologies operate independently and are not influenced by each other. If the pressure does not exceed 40 barg; 580 psig, we recommend BM 26 ADVANCED with the OPTIWAVE 7300 C FMCW radar level meter option.

By adding an externally-mounted analogue transmitter to these device combinations, equipment condition can be monitored and a predictive maintenance strategy is possible: maintenance can be planned sufficiently in advance, and at DCS level, by comparing the measuring results of the analogue transmitter with those of the radar meter.



Displacer

The measuring principle

The BW 25 level indicator works according to the displacer principle. In this principle, the length of the displacement element rod corresponds to the measuring range. The body, which is suspended on a measuring spring, is immersed in the liquid where it determines the lifting force that is proportional to the displaced mass of the liquid (Archimedean principle). Any change to the weight of the rod corresponds to a change in the length of the spring and is therefore a measure of the level. The extension of the length of the spring, and thereby the measuring stroke, are transmitted to a display from the measuring room.

Highlights BW 25:

- Suitable for use under extreme process conditions
- Resistant to temperatures ranging from -60 to +400 °C; -76 to +752 °F and pressures up to 400 barg; 5800 psig
- Level and separating layer measurement
- Modular design, which makes swapping or retrofitting possible without interrupting the process
- Pressure-proof isolation of the measuring and displaying room

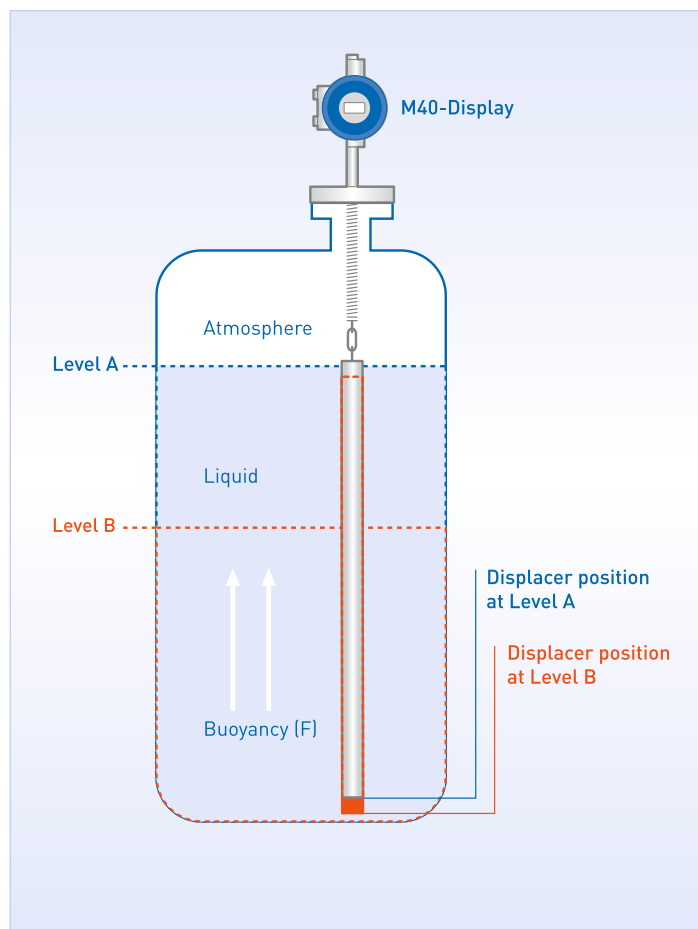

Industries:

- Petrochemical
- Chemical
- Power generation



Displacer BW 25 – Sovereign even under extreme process conditions

Whether you are dealing with water or watery liquids, acids or alkalis, organic or inorganic solvents, the level or the interface: The BW 25 is a true all-rounder, which is even suitable for use under extreme process conditions.

The displacer independently handles high temperatures of up to +400 °C; +752 °F and enormous pressures of up to 400 barg; 5800 psig. It is also capable of determining and measuring the interface between two immiscible liquids of different densities.

Thanks to its modular design, the BW 25 provides maximum flexibility in every respect. With plug & play capability, retrofitting components such as contacts, power outputs, etc. can be done in a flash without interrupting the process.

And what if installation into the tank is made difficult by an agitator? No problem: Because for this case, there is a reference vessel which allows installation from the side.



BW 25 with M9 display

Potentiometric process

Highlights:

- Measurement independent of media properties
- Not sensitive to adhesives and foam
- Up to 3 m; 9.8 ft probe length
- Defined empty reporting function
- Potted design
- Quick response time
- Automatic position detection
- Level measurement beyond 50 mm; 1.97"
- High temperature resistance (+140 °C; +284 °F)

The measuring principle

The BM 500 level meter works according to the potentiometric measuring principle and can only be used with a minimum conductivity of 50 $\mu\text{S}/\text{cm}$ for all electrically conductive media (e.g. pure water).

The level probe (sensor) consists of a low-resistance measuring tube, which is immersed in an electrically conductive liquid. An AC generator runs a higher frequency current through the measuring tube. A voltage is taken from between the probe and the tank wall and sent to an amplifier. In homogeneous conditions in the medium, this is proportional to the level.

The potentiometric measuring method is particularly suitable for measuring levels in small vessels containing tough, pasty or strongly adhesive media. The electronic evaluation unit is integrated in the signal converter and supplies a level-proportional output signal of 4 to 20 mA.

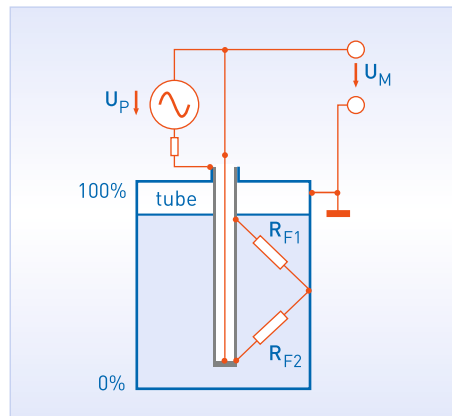

BM 500 for hygienic applications

Industries:



- Food and beverage
- Pharmaceutical



Whether you are dealing with fruit juice, ketchup, beer, toothpaste or mustard: for tough, pasty or highly adhesive media, the BM 500 level meter is the first choice.

Especially in small tanks, the potentiometric measuring process can make full use of its advantages. Thus, the BM 500 already measures starting at a level of 50 mm; 1.97" and wins you over with its very fast response time.

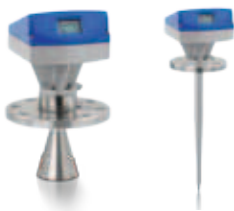
Hygienic adaptation for the food and beverage industry and for the pharmacy is guaranteed by a process welded sleeve. CIP and sterilization processes are not a problem thanks to the high temperature resistance of the BM 500.







	2-wire FMCW radar for simple applications	2-wire FMCW Radar for liquid applications	2-wire FMCW radar for solid applications
	BM 702 A	OPTIWAVE 5200 C/F	OPTIWAVE 6300 C
			
Frequency range	X-band/10 GHz	X-band/10 GHz	K-band/24...26 GHz
Measurable products	Liquids, pastes & slurries	Liquids, pastes & slurries	Powders, granulates & bulk solids
Level/interface	+/-	+/-	+/-
Measuring range	0.5...30 m; 1.6...98.4 ft	1...30 m; 3.3...98 ft	0.2...80 m; 0.7...262.4 ft
Dielectric constant ϵ_r	≥ 1.5	≥ 1.8	≥ 1.5
Accuracy	± 10 mm; ± 0.4 " optional ± 5 mm; ± 0.2 "	± 10 mm; ± 0.4 " optional ± 5 mm; ± 0.2 "	± 10 mm; ± 0.4 "
Outputs	mA (HART®)	mA (HART®) FF / PROFIBUS® PA (pending)	mA (HART®); optional: 2nd current output mA (non-HART®)
Power supply	2-wire: 14.5...30 VDC	2-wire: 12...30 V DC (non-Ex and Ex i) 16...36 V DC (Ex d)	2-wire: 14...30 VDC (non-Ex and Ex i), 20...36 VDC (Ex d)
Housing material	Aluminium	Aluminium, stainless steel	Aluminium, stainless steel
Ambient temperature	-40...+70°C; -40...+158°F	-40...+80°C / -40...+176°F	-40...+80°C; -40...176°F
Protection category	IP66/67; NEMA6-6X	IP 66/67; NEMA4X/6P	IP66/67; NEMA4X/6P
Flange system			
Process connection			
Thread	G1 1/2; 1 1/2" NPT	G1 1/2; 1 1/2" NPT	G1 1/2; 1 1/2" NPT
EN	DN50...200 in PN16, 40	DN50...200; PN16, 40	DN80...200 in PN16, 40
ASME	2...8" in 150 lb/300 lb	2...8"; 150 lbs, 300 lbs	3...4" in 150 lb/300 lb, 6...8" in 150 lb
JIS	50...150A in 10K/20 K, 200 A in 10K/16K	50...200A in 10K	80...100A in 10K
Hygienic	DIN 11851: DN50...80 SMS 1145: 51...76 mm Tri-clamp ISO 2852: 2...4"	-	-
Pressure range			
Process	-1...40 barg; -14.5...580 psig, Wave Stick antenna: -1...16 barg; -14.5...232 psig, others on request	-1...40 barg; -14.5...580 psig, higher on request	PP Drop antenna: -1...16 barg; -14.5...232 psig all other antennas: -1...40 barg; -14.5...580 psig,
Temperature range			
Process	-40...+250°C; -40...+482°F, Wave Stick antenna: -40...+150°C; -40...+302°F, others on request	-60 ...+250°C; -76 ...+482°F, higher on request	PP Drop antenna: -40...+100°C; -40...+212°F PTFE Drop antenna: -50...+150°C; -58...+302°F Horn antennas with distance piece: -50...+200°C; -58...+392°F
Materials			
Wetted parts	Stainless steel 1.4571 (316Ti), Hastelloy® C, titanium, tantalum, PP, PTFE, others on request	Stainless steel, PP, PTFE, others on request	Horn antenna: stainless steel (1.4404/316L) Drop antenna: PTFE, PP; a PP or PTFE flange plate as option
Gaskets	FPM, FPM/FEP, Silicone/FEP, PFA Kalrez®, 2035, 6230, 6375, 4079, others on request	FKM/FPM, Kalrez® 6375, EPDM, PFA, others on request	FKM/FPM, Kalrez® 6375, EPDM, others on request
Approvals			
Ex	ATEX, others on request	ATEX, IECEx, cFMus, NEPSI Gost (pending)	ATEX, FM, CSA, INMETRO, NEPSI, IECEx, Gost
Miscellaneous	-	SIL2, CRN	-

	2-wire FMCW radar for liquid applications	2-wire FMCW radar for marine applications
	OPTIWAVE 7300 C	OPTIWAVE 8300 C Marine ¹⁾
		
Frequency range	K-band/24...26 GHz	K-band/24...26 GHz
Measurable products	Liquids, pastes & slurries	Liquids
Level/interface	+/-	+/-
Measuring range	0.2...80 m; 0.7...262.4 ft	0.2...40 m; 0.7...131.2 ft
Dielectric constant ϵ_r	≥ 1.5	≥ 1.5
Accuracy	± 3 mm; ± 0.12 "	± 2 mm; ± 0.08 "
Outputs	mA (HART®); optional: 2nd current output mA (non-HART®)	mA (HART®)
Power supply	2-wire: 14...30 VDC (non-Ex and Ex i), 20...36 VDC (Ex d)	2-wire: 14...30 VDC (non-Ex and Ex i)
Housing material	Aluminium, stainless steel	Stainless steel
Ambient temperature	-40...+80°C; -40...176°F	-40...+70°C; -40...158°F
Protection category	IP66/67; NEMA4X/6P	IP66/67; NEMA4X/6P
Flange system		
Process connection		
Thread	G1 1/2; 1 1/2" NPT	-
EN	DN40...150 in PN16, 40, 63, 100; DN200 in PN16, 40	DN125 in PN16
ASME	1 1/2...4" in 150 lb/300lb/600lb/900lb, 6" 150 lb/300 lb, 8" 150 lb	-
JIS	40...100A in 10K	-
Hygienic	Tri-Clamp 2", Bio Control DN50, DIN 11851 DN50, SMS 51	-
Pressure range		
Process	PP Drop antenna: -1...16 barg; -14.5...232 psig PTFE Drop antenna: -1...40 barg; -14.5...580 psig, Hygienic -1...10 barg; -14.5...145 psig, Horn antennas: -1...100 barg; -14.5...1450 psig	Horn antenna: -1...40 barg; -14.5...580 psig
Temperature range		
Process	PP Drop antenna: -40...+100°C; -40...+212°F PTFE Drop antenna: -50...+150°C; -58...+302°F Hygienic antenna: -20...+150°C; -4...302°F Horn antennas with distance piece: -50...+200°C; -58...+392°F	Horn antenna: -40...+200°C; -40...+392°F
Materials		
Wetted parts	Horn antenna: stainless steel (1.4404/316L) or Hastelloy® C-22 [2.4602] Drop antenna: PTFE, PP; a PP or PTFE flange plate as option	Horn antenna: stainless steel (1.4404/316L) or 3% Molybden Mo
Gaskets	FKM/FPM, Kalrez® 6375, EPDM, others on request	FKM/FPM, Kalrez® 6375, others on request
Approvals		
Ex	ATEX, FM, CSA, INMETRO, NEPSI, IECEx, Gost	ATEX
Miscellaneous	§ 19 WHG	Marine approvals : DNV, ABS, GL, LR, BV, CCS, NK, RINA, KR. Antenna purging system + pressure sensor



1) marketed through KROHNE Skarpenord sales office

	2-/4-wire ultrasonic level meter for small tanks	2-/4-wire ultrasonic level meter for small and medium-sized tanks	2-/4-wire ultrasonic level meter for medium-sized tanks
	OPTISOUND 3010	OPTISOUND 3020	OPTISOUND 3030
			
Frequency range	70 kHz	55 kHz	35 kHz
Measurable products	Liquids and solids	Liquids and solids	Liquids and solids
Level/interface	+/-	+/-	+/-
Measuring range	Liquids: 0.25...5 m; 0.8...16.4 ft solids: 0.25...2 m; 0.8...6.6 ft	Liquids: 0.4...8 m; 1.3...26.2 ft solids: 0.4...3.5 m; 1.3...11.5 ft	Liquids: 0.6...15 m; 2...49.2 ft solids: 0.6...7 m; 2...23 ft
Dielectric constant ϵ_r	-	-	-
Accuracy	± 4 mm; ± 0.16 "	± 6 mm; ± 0.24 "	± 6 mm; ± 0.24 "
Outputs	mA (HART®)	mA (HART®)	mA (HART®)
Power supply	2-wire: 14...36 VDC (14...30 VDC Ex i) 4-wire: 20...72 VDC, 20...253 VAC	2-wire: 14...36 VDC (14...30 VDC Ex i) 4-wire: 20...72 VDC, 20...253 VAC	2-wire: 14...36 VDC (14...30 VDC Ex i) 4-wire: 20...72 VDC, 20...253 VAC
Housing material	Plastic, aluminium, stainless steel	Plastic, aluminium, stainless steel	Plastic, aluminium, stainless steel
Ambient temperature	-40...+80°C; -40...+176°F	-40...+80°C; -40...+176°F	-40...+80°C; -40...+176°F
Protection category	IP66/67; NEMA4, 4X, 6	IP66/67; NEMA4, 4X, 6	IP66/67; NEMA4, 4X, 6
Flange system			
Process connection			
Thread	G1 1/2, others on request	G2, others on request	-
EN	On request	On request	Collar flange DN100, others on request
ASME	On request	On request	On request
JIS	-	-	-
Pressure range			
Process	-0.2...2 barg; -2.9...29 psig	-0.2...2 barg; -2.9...29 psig	-0.2...1 barg; -2.9...14.5 psig
Temperature range			
Process	-40...+80°C; -40...+176°F	-40...+80°C; -40...+176°F	-40...+80°C; -40...+176°F
Materials			
Wetted parts	PVDF	PVDF	1.4301, UP, 1.4571 (316 Ti)
Gaskets	EPDM	EPDM	EPDM
Approvals			
Ex	ATEX	ATEX	-
Miscellaneous	-	-	-

2-wire TDR guided radar for storage or simple process applications	2-wire TDR guided radar for general applications	2-wire TDR guided radar for solid, liquid and interface applications	2-wire TDR guided radar for marine applications
OPTIFLEX 1100 C	OPTIFLEX 2200 C/F	OPTIFLEX 1300 C	OPTIFLEX 4300 C Marine ¹⁾
			
1 GHz	1 GHz	2 GHz	2 GHz
Liquids and solids	Liquids and solids	Liquids and solids	Liquids and solids
+/-	+/-	+/+	+/+
0.7...20 m; 2.3...65.6 ft	0.6...40 m; 2...131 ft	0.2...35 m; 0.7...115 ft	0.2...35 m; 0.7...115 ft
≥ 1.6	≥1.4 [1.1]	≥1.4 [1.1]	≥1.4 [1.1]
±10 mm; ±0.4" (liquids) ±20 mm; ±0.8" (solids)	±10 mm; ±0.4" ± 3 mm; ±0.12"	±3 mm; ±0.12"	±2 mm; ±0.08"
mA	mA (HART®) FF/PROFIBUS® PA (pending)	mA (HART®) optional: 2nd current output mA (non-HART®)	mA (HART®)
2-wire: 14...30 VDC	2-wire: 12...30 VDC (non-Ex and Ex i), 16...36 VDC (Ex d)	2-wire: 14...30 VDC (non-Ex and Ex i), 20...36 VDC (Ex d)	2-wire: 14...30 VDC (non-Ex and Ex i)
Aluminium	Aluminium, stainless steel	Aluminium, stainless steel	Stainless steel
-40...+80°C; -40...+176°F	-40...+80°C; -40...+176°F	-40...+80°C; -40...176°F	-40...+80°C; -40...+176°F
IP 66/67	IP66/67; NEMA4X/6P	IP66/67; NEMA6-6X	IP66/67
G3/4 or G1, 3/4" NPT or 1" NPT	G1/2...1 1/2, 1/2"...1 1/2" NPT	G1/2...1 1/2, 1/2"...1 1/2" NPT	G3/4
Screw-on flanges available as accessories	DN25...150 in PN10...40, DN200 in PN16, 40, others on request	DN25...150 in PN16...100, DN200 in PN16, 40, others on request	DN125 in PN16
Screw-on flanges available as accessories	1...8" in 150 lb/300 lb, others on request	1...4" in 150...900/1500 lb, 6" in 150 lb/300 lb, 8" 150 lb, 1" 2500 lb others on request	--
Screw-on flanges available as accessories	40...200A in 10K, others on request	40...100A in 10K, others on request	-
-1...16 barg; -14.5...232 psig	-1...40 barg; -14.5...580 psig	-1...100 barg; -14.5...1450 psig, optional 300 barg; 4351 psig	-1...40 barg; -14.5...580 psig
-50...+100°C; -58...212°F	-50...+150°C; -58...+302°F, optional +300°C; +572°F	-50...+250°C; -58...+480°F, optional +300°C; +570°F	-
Cable : stainless steel 1.4404 (316) Coaxial : stainless steel 1.4435/1.4404 (316L)	Stainless steel, Hastelloy®, others on request	Stainless steel 1.4401 (316), 1.4435/1.4404 (316L), Hastelloy® C-22 (2.4602), others on request	Stainless steel
EPDM	FKM/FPM, Kalrez® 6375, EPDM, others on request	FKM/FPM, Kalrez® 6375, EPDM, others on request	FKM/FPM, Kalrez® 6375, EPDM, others on request
CE	ATEX, IECEx, FM, CSA, NEPSI Gost (pending)	ATEX, FM, CSA, Gost, NEPSI, IECEx	ATEX
-	SIL2	WHG	Marine approvals: DNV, ABS, GL, LR, BV, CCS, NK, KR

1) marketed through KROHNE Skarpenord sales office

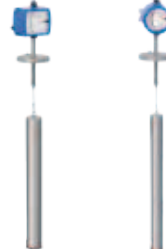
	Magnetic bypass level indicator (MLI)	Magnetic bypass level indicator for liquid and interface applications	2-wire FMCW radar on magnetic bypass level indicator for liquid applications
	BM 26 BASIC/ADVANCED	BM 26 A	BM 26 W
			
Measuring principle	Float	Float	Float/radar
Measurable products	Liquids	Liquids	Liquids
Level/interface	+/-	+/+	+/-
Measuring range	0.3...5.3 m; 1...17.4 ft, longer devices on request	0.3...5.5 m; 1...18 ft, longer devices on request	0.3...5.4 m; 1...17.7 ft, longer devices on request
Product characteristics	Density: 0.58...2 kg/l; 36.2...124.8 lb/ft ³	Density: ≥0.48...3 kg/l; 30...187.3 lb/ft ³ , lower on request	Density: ≥0.52 kg/l; ≥32,5 lb/ft ³ , lower on request
Accuracy	±10 mm; ±0.4"	±10 mm; ±0.4"	±10 mm; ±0.4"
Outputs	mA (HART®), PROFIBUS® PA, FOUNDATION™ Fieldbus, switching outputs	mA (HART®), PROFIBUS® PA, FOUNDATION™ Fieldbus, switching outputs	mA (HART®), switching outputs
Power supply	12...35 VDC	8...35 VDC (non-Ex), 8...30 VDC	Radar transmitter – 2-wire: 14...30 VDC (non-Ex and Ex i) 20...36 VDC (Ex d)
Housing material (transmitter)	Aluminium	Aluminium	Aluminium, stainless steel
Ambient temperature	-40...+80°C; -40...+176°F	-40...+85°C; -40...+185°F	-40...+80°C; -40...+176°F
Protection category	IP68	IP68; NEMA6-6X	IP66/67; NEMA4x/6P
Flange system			
Process connection			
Thread	G1/2, 3/4; 1/2, 3/4 NPT	On request	On request
EN	DN15...50 in PN40...100	DN15...50 in PN40, optional PN 100	DN15...50 in PN40
ASME	1/2...2" in 150 lb/300 lb	1/2...2" in 150...300 lb, optional 600 lb	1/2...2" in 150 lb/300 lb
Pressure range			
Process	-1...40 barg; -14.5...580 psig	-1...40 barg; -14.5...580 psig, HP version 100 bar, higher on request	-1...40 barg; -14.5...580 psig, HP version 100 bar
Temperature range			
Process	-40...+300°C; -40...+572°F	-196...+300°C; -321...+572°F	-50...+200°C; -58...+392°F
Materials			
Wetted parts	Stainless steel, Hastelloy®, others on request	Stainless steel 1.4404 (316L), 1.4571 (316Ti), PTFE, PVC, PVDF, others on request	Stainless steel 1.4404 (316L), others on request
Gaskets	Aramid, PTFE, Graphite	Aramid, PTFE, Graphite	Aramid, PTFE, Graphite
Approvals			
Ex	ATEX, Gost	ATEX, Gost	ATEX, Gost
Miscellaneous	-	-	-

	2-wire TDR guided radar in a reference chamber for liquid and interface applications	The broadband displacer system for high pressures and temperatures	4-wire, potentiometric
	BM 26 F	BW 25	BM 500
			
Measuring principle	TDR	Displacer	Potentiometric
Measurable products	Liquids	Liquids	Liquids and pastes
Level/interface	+/+	+/+	+/-
Measuring range	0.3...5.5 m; 1...18 ft, longer devices on request	0.3...5.5 m; 1...18 ft, longer devices on request	0.2...3 m; 0.7...9.8 ft
Product characteristics	Dielectric constant ϵ_r : ≥ 1.4 (1.1)	Density: ≥ 0.45 kg/l; ≥ 28.09 lb/ft ³	Electrical conductivity: ≥ 50 μ s/cm
Accuracy	± 3 mm; ± 0.12 "	<1.5% full scale value	$\pm 0.5\%$
Outputs	mA (HART®) optional: 2nd current output 4...20 mA (non-HART®)	mA (HART®) switching outputs	mA
Power supply	Radar transmitter – 2-wire: 14...30 VDC (non-Ex and Ex i), 20...36 VDC (Ex d)	12...30 VDC	4-wire: 18...36 VDC (non-Ex and Ex i)
Housing material (transmitter)	Aluminium, stainless steel	Aluminium, stainless steel	Stainless steel
Ambient temperature	-40...+80°C; -40...+176°F	-40...+60°C; -40...+140°F	-20...+60°C; -4...+140°F
Protection category	IP66/67; NEMA6-6X	IP67; NEMA4X	IP67; NEMA4X
Flange system			
Process connection			
Thread	On request	On request	G1 hygienic via adapter system
EN	DN15...50 in PN40	DN50...100 in PN16...400	-
ASME	1/2...2" in 150 lb/300 lb	2...4" in 150 lb...2500 lb	-
Pressure range			
Process	-1...40 barg; -14.5...580 psig, HP version 100 bar higher on request	-1...400 barg; -14.5...5800 psig, others on request	-1...16 barg; -14.5...232 psig
Temperature range			
Process	-50...+300°C; -58...+572°F	-40...+400°C; -40...+752°F	-20...+140°C; -4...+284°F
Materials			
Wetted parts	Stainless steel, others on request	Stainless steel 1.4404 (316L), others on request	Stainless steel 1.4404 (316L)
Gaskets	Aramid, PTFE, Graphite	-	-
Approvals			
Ex	ATEX	ATEX	-
Miscellaneous	-	-	EHEDG



OPTISWITCH 3000
Vibration level
switch for solids



OPTISWITCH 4000
Vibration level switch for
liquids for simple applications



OPTISWITCH 5000
Vibration level switch for liquids
for process applications



LS 6500
Electromagnetic switch



LS 72XX
Conductive switch
with 1-4 switch points

Level switch

Level switch

The measuring principle

The oscillating element of the OPTISWITCH consists of two paddle-shaped oscillating rods (1), which are coupled via a membrane (2). Together with the piezo ceramics (3), the rods and the membrane form an electromechanical resonator, which oscillates in the air at its own resonant frequency. The piezos are mechanically mounted and are therefore not subject to any temperature shock limits. If the oscillating rods are covered with fill goods, the oscillating frequency and amplitude change. This means: when the oscillating probe is covered with fill goods, the effective mass of the system increases by the product particles moved by the oscillating rods. This results in a reduction of the frequency of the spring-mass-system.

The frequency change depends on the density of the fill goods and the immersion depth of the oscillating rods. The oscillating frequency of the resonator logged by the piezo ceramics is detected in a built-in transducer and is converted into a switching command when a preset threshold value is exceeded. Because this frequency change in solids is frequently only very slight, it is the amplitude change that is detected in this case. For solids, the fork is also considerably larger, in order to attain greater sensitivity by increasing the effective surface area.

Some typical applications are over-fill protection and dry-run protection. Thanks to its very simple and rugged design, the OPTISWITCH can be used independently of the essential physical and chemical product characteristics in nearly all applications.

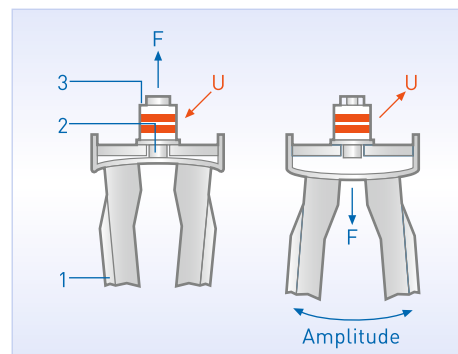

The Piezo effect

Piezo ceramics can be operated in two directions of effect. When an electrical voltage (U) is applied to piezo ceramics, they become physically deformed (F – actuator effect). Conversely, piezo ceramics convert mechanical deformation into an electrical voltage (sensor direction of effect). Both directions of effect are used for vibration level switches.

Highlights:

- Rugged oscillating fork, high abrasion resistance
- Exactly reproducible switching point without adjustment
- Continuous self-monitoring of correct oscillating frequency, corrosion and cable breakage to the Piezo drive
- Measurement independent of media properties such as viscosity, dielectric constant (ϵ_r) or electrical conductivity
- Not sensitive to adhesions (foam), pressure and temperature changes and external vibrations
- Detection of solids with density $\geq 0.008 \text{ kg/l}$; 0.5 lb/ft^3
- Detection of liquids with density $\geq 0.5 \text{ kg/l}$; 31.2 lb/ft^3
- Wide temperature and pressure range: $-50 \dots +250 \text{ }^\circ\text{C}$; $-58 \dots +482 \text{ }^\circ\text{F}$, max. 64 barg; 928.4 psig
- Hygienic design with polished surface
- Recurring test as per WHG via test button (with SU 501)
- Detection of solids in water
- Functional safety: up to SIL2 in a single channel architecture, and up to SIL3 in a multiple channel, redundant architecture



OPTISWITCH – The rugged solution for solids and liquids

In the construction materials industry, heavy dust build-up and the mechanical stresses are a challenge for any limit switch. This is not a problem for OPTISWITCH: The rugged unit detects the limit in the silo independently of the properties of the bulk goods and reliably warns against overfilling. OPTISWITCH even masters tall, narrow silos due to the product-independent switching point. This is especially beneficial for rapid or recurring changes of bulk goods. Even aerosil and other very light bulk goods must be reliably and safely detected using OPTISWITCH.

Thanks to the exact reproducibility of the switching point and the integrated function monitoring, the OPTISWITCH can be used as overflow protection as per §19 WHG, dry-run protection or pump protection. Neither adhesions on the oscillating fork nor container vibrations have an impact on the measurement.

Industries:

- Chemical and petrochemical
- Food and beverage
- Pharmaceutical
- Water and wastewater
- Building material
- Plastic processing

Electromagnetic limit switch for liquids and pastes

Highlights:

- Measurement independent of media properties
- Not sensitive to adhesives and foam
- No blockage of the pipeline, no pressure loss
- Independent of the position and vibration
- Hygienic installation by means of a hygienic process weld sleeve, nearly flush with the front
- Dry-run protection beyond a nominal width of DN15

The measuring principle

The electromagnetic wave measuring process allows for universal use even when the media changes. The electromagnetic wave penetrates the medium and, depending on the respective relative permittivity, a phase shift occurs which is then evaluated.

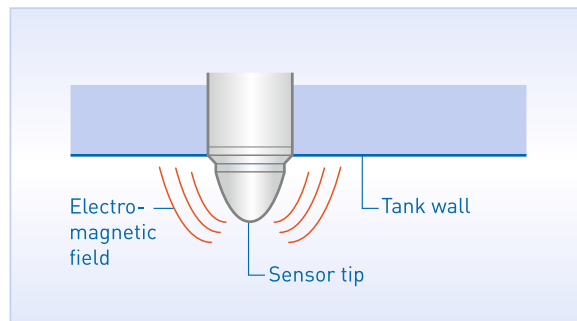

Electromagnetic switch LS 6500/LS 6600

Industries:

- Food and beverage
- Pharmaceutical



LS 6500

The electromagnetic switches of the LS 6500/LS 6600 series handle the various types of media in the food and beverage industry and in the pharmaceuticals industry: whether you are dealing with dairy products, yoghurt, toothpaste or even cooking oil, the hygienic switches safely and reliably detect the level or serve as dry-run protection. The measurement remains unaffected by foam, condensate or build-up of deposits. Another advantage of this family of switches is the very fast response time of the devices and the high immunity to vibrations.

Conductive limit switches

The measuring principle

Conductive probes detect the resistance of the fill goods when the goods cover their electrodes. A small AC current is generated which is evaluated in the electronics unit and converted into switching commands. The switching signal is determined by the length and installation position of the probe and its sensitivity setting.



LS 7200

LS 7000 conductive switch

Stub, rod or multi-rod electrode? The hygienic conductive probes of the LS 7000 family provide the right solution for any installation situation.

The probe rods are optionally made of stainless steel or coated in order to guarantee their insensitivity to foam and adhesions.

For changing media with widely differing degrees of conductivity, the sensitivity of the probe can be switched over via the control cable.



The hygienic, dead zone-free installation of the LS 7000 series is ensured via a number of different hygienic process connections.



Highlights:

- Optimized flow geometry
- Precise switching point
- Hygienic, dead zone-free installation
- Stub, rod or multi-rod electrodes are available
- Probes can be shortened as needed
- Compact or remote version (electronics in the switchgear cabinet)

Industries:

- Food and beverage
- Pharmaceutical

	Vibration level switch for solids	Vibration level switch for liquids for simple applications	Vibration level switch for liquids for process applications
	OPTISWITCH 3X00	OPTISWITCH 4000	OPTISWITCH 5X00
			
Measuring principle	Vibration	Vibration	Vibration
Measurable products	Solids and solids in water	Liquids	Liquids
Level/interface	+/+ (solids in water)	+/-	+/-
Standard length	220 mm; 8.7"	66 mm; 2.6"	66 mm; 2.6"
Length with tube extension	0.3...6 m; 11.8"...20 ft	-	0.08...6 m; 3"...20 ft
Length with cable extension	0.3...80 m; 11.8"...262.4 ft	-	-
Depends on product characteristics	Density: ≥0.008 kg/l; ≥0.5 lb/ft ³	Density: ≥0.7 kg/l; ≥43.7 lb/ft ³	Density: ≥0.5 kg/l; ≥31.2 lb/ft ³
Outputs	Relay, transistor, contactless switch, 2-wire output	Transistor, contactless switch	Relay, transistor, contactless switch, 2-wire output, Namur
Power supply	Relay and contactless switch: 20...253 VAC/DC transistor output: 10...55 VDC	Contactless switch: 20...253 VAC/DC transistor output: 10...55 VDC	Relay and contactless switch: 20...253 VAC/DC transistor output: 10...55 VDC
Housing material	Plastic, aluminium, stainless steel	Plastic, stainless steel	Plastic, aluminium, stainless steel
Ambient temperature	-40...+70°C; -40...+158°F	-40...+70°C; -40...+158°F	-40...+70°C; -40...+158°F
Protection category	IP66/67; NEMA4, 4X, 6	IP65/67; NEMA4, 4X, 6	IP66/67; NEMA4, 4X, 6
Flange system			
Process connection			
Thread	G1 1/2; 1 1/2" NPT	G1/2, 1; 3/4", 1" NPT	G3/4, 1; 3/4", 1" NPT
EN 1092-1	On request	-	≥DN25 in PN16...64
ASME B 16.5	On request	-	≥1" in 150...300 lb
Pressure range			
Process	-1...16 barg; -14.5...232 psig	-1...64 barg; -14.5...928.2 psig	-1...64 barg; -14.5...928.2 psig
Temperature range			
Process	-50...+250°C; -58...+482°F	-40...+150°C; -40...+302°F	-50...+250°C; -58...+482°F
Materials			
Wetted parts	Stainless steel 1.4435/1.4404 (316L), 1.4462 (318S13)	Stainless steel 1.4435/1.4404 (316L), others on request	Stainless steel 1.4571 (316Ti), Hastelloy® C, enamel, ECTFE, PFA
Gasket	Klingersil® C-4400 (for thread)	Klingersil® C-4400 (process seal)	Klingersil® C-4400 (for thread)
Approvals			
Ex	ATEX	-	ATEX
Miscellaneous	-	§19 WHG	§19 WHG, shipping approvals, SIL 2

	Electromagnetic switch	Conductive switch with 1-4 switch points
	LS 6500/LS6600	LS 72XX
		
Measuring principle	Electromagnetic switch	Conductive switch
Measurable products	Liquids and solids	Liquids
Level/interface	-	-
Standard length	13/17 mm; 0.5/0.7"	0.2...1.5 m; 7.8...59"
Length with tube extension	100/250 mm; 3.9/9.8"	-
Length with cable extension	-	-
Depends on product characteristics	Dielectric constant (ϵ_r) ≥ 1.5	Conductive products
Outputs	Transistor	Transistor
Power supply	12...36 VDC, max. 70 mA	18...36 VDC, max. 10 mA
Housing material	Stainless steel	Stainless steel
Ambient temperature	-40...+85°C; -40...+185°F	-20...+60°C; -4...+140°F
Protection category	IP66/67; NEMA4, 4X, 6	IP66/67; NEMA4, 4X, 6
Flange system		
Process connection		
Thread	G1/2	G1/2, 1
EN 1092-1	-	-
ASME B 16.5	-	-
Pressure range		
Process	-1...16 barg; -14.5...232 psig	-1...16 barg; -14.5...232 psig
Temperature range		
Process	-20...+85°C; -4...+185°F	-20...+140°C; -4...+284°F
Materials		
Wetted parts	Stainless steel 1.4404 (316L)	Stainless steel 1.4404 (316L)
Gasket	-	-
Approvals		
Ex	ATEX	-
Miscellaneous	EHEDG	EHEDG



K HNE



Beyond the highest requirements



Beyond the highest requirements: KROHNE services

For us, service starts at our first contact with you and lasts as long as the life of our systems installed at your plant.

Quality and reliability are key to maintaining the highest service standards. All KROHNE Feeder Factories are ISO 9001 certified. In fact, long before ISO 9000 existed, KROHNE was manufacturing to the highest industrial standards. Now certification exists in every factory to demonstrate that we not only fulfil ISO requirements but have passed the ISO certification procedure every three years since the standard was introduced.

If you install and operate any KROHNE product by following our operating instructions correctly, problems shouldn't occur. If they do, we will provide you with all the technical support and service you need.

Choose from maintenance and service contracts tailored to suit all business sizes and needs: Spare parts and consumables, field service and on-site repair, returns, workshop repair, helpdesk.

KROHNE Academy

The KROHNE Academy is a series of seminars organised in collaboration with leading automation companies aimed at plant engineers, operators and contractors across the process industries. It brings industry experts together to provide an insight into the various technologies, industrial standards and procedures that plant operators can find themselves faced with.

Taking place in various countries, KROHNE Academy seminars address key operating issues, from plant safety to ways of increasing plant efficiency and controlling costs, and show possible solutions. They also provide an ideal opportunity for you to speak to the experts and benefit from their vast application knowledge.

Learn more about KROHNE Academy at www.krohne.com

KROHNE Academy online

KROHNE Academy online gives you direct access to the knowledge. The Web Based Trainings are audio enhanced, interactive courses and are published on this eLearning platform. As with its on-site seminars, the online KROHNE academy learning material is vendor agnostic and not specific to individual products and/or industries. The main focus of each course relates to a measurement technology such as Variable Area, Vortex, Ultrasonic or Mass flow or to a more general topic such as the basics of gas measurement or pipeline leak detection.

Register now for free and start your training at <http://academy-online.krohne.com>

Engineering services through all project stages

- Project management
- Control and asset management systems in project concept phase
- Basic engineering based on the specification required by the user
- Detail engineering phase
- Commissioning services
- On-site start-up and commissioning
- Product training (on-site)
- Calibration services

Additional online services:

(Find them at www.krohne.com)

- **KROVASYS 4**
Selection and calculation tool for variable area flowmeters.
- **Planning tool for water & wastewater industry**
The planning tool for wastewater treatment plants as well as water and wastewater applications for generating tender documents covering flow, level, analysis, pressure and temperature.
- **PiCK**
Get any information related to your KROHNE product from our dedicated online resource PiCK. Just enter your serial number, and key material like manuals, Quick Starts and calibration documents is at your fingertips.



Calibration at KROHNE: Certainty that you can count on

High degree of accuracy and reproducibility, including maximum reliability and efficiency – this not only applies to each meter from KROHNE, but also to our calibration devices. KROHNE operates calibration stations, both for radar and for TDR meters, which serve as a model for dimensioning and accuracy. The calibration sections are over 30 m; 98.4 ft long and the operation is almost completely automated. Comprehensive safety measures guarantee a measurement which is independent of external interference along with reliable protection of the operators.

Calibration in the example TDR level meter

TDR level meters with rod or wire-type probes in single or dual design can be calibrated on a 29 m; 95.1 ft stretch. Four points are measured as standard, compared to the reference values of a laser measurement and the instrument is calibrated accordingly. The values are then measured once more to check that they are within the tolerance range. The calibration process also includes a stability test in which a certain reflector position is continually measured for one minute. The deviation of the measuring instrument must lie within the tolerance range. The accuracy that can be achieved with this system is 0.2 mm; 0.008"



KROHNE proved: Expect more – achieve more

Every one of our level meters is given a thorough inspection before leaving our factory.

We call these specific measurements, tests and factory inspections “KROHNE proved”. They go well beyond any legal requirements, thus guaranteeing our customers not only compliance with specified technical data but also the precise and reliable use of our devices under extremely difficult conditions.

For example, we subject each OPTIWAVE level radar device to a complete series of temperature change tests.

During these tests, the electronics units are exposed to cyclical temperature changes between -20 and +60 °C; -4 and +140 °F. Breakdowns in the field are thus kept to a minimum.

And we will not budge on these strict tests. After all, we want to be sure that we have a clear picture of the quality and performance capability of the products we offer our customers.

This is the basic principle by which you can measure any device leaving our factory, now and in the future.

KROHNE

Product overview

- Electromagnetic flowmeters
- Variable area flowmeters
- Ultrasonic flowmeters
- Mass flowmeters
- Vortex flowmeters
- Flow controllers
- Level meters
- Temperature meters
- Pressure meters
- Analysis products
- Products and systems for the oil & gas industry
- Measuring systems for the marine industry



Contact

Head office
KROHNE Messtechnik GmbH
Ludwig-Krohne-Str. 5
47058 Duisburg
Germany
Tel.: +49 203 301 0
Fax: +49 203 301 103 89
info@krohne.de

Global companies and representatives
The current list of all
KROHNE contacts and
addresses can be found at:
www.krohne.com